

DIGITAL PANEL INSTRUMENTS

Digital panel instruments for sophisticated industrial applications. Compact digital displays, bargraphs as well as large-screen displays for microprocessor-controlled signal processing of analog measuring values via 16-bit A/D - converter: DC V/mA, DC V/mA-differential measurement, DC mV/ μ A, AC V/A, resistance measurement, recognition of rotated angles, frequency measurement, temperature measurement PT100, PT1000 and thermocouples.

Advantages:

Multiple inputs per instrument, numerous output options, robust closed front-panel-housings in all Norm sizes, brilliant and reliably readable LED-displays, low-reflecting filter plates.

Inputs on pluggable screw terminals and D-Sub-connector, three- to five-digit displays, bargraphs with 1- or 2-times 10 - 50 segments, user-friendly programmable operating parameters, indicating range and decimal point freely programmable, galvanic insulated supply voltage, dimensional signs on the filter plate, neutral frontal view, custom-designed modifications of type instruments.

Current/voltage | Frequency | ProfiBus L2DP |

02

DA08/DA10 (48x24/72x24)	page 2/1
DA12 (72x36)	page 2/3
DA13 (96x24/96x48)	page 2/6
DBA (bargraphs)	page 2/13
DA20/DA25 (144x36)	page 2/23
DA55/DA75/DA100 (large-screen displays)	on request
M1-Serie (48x24)	page 2/27
(72x36)	page 2/33
(96x24)	page 2/39
(96x48)	page 2/45
M2-Serie (96x48)	page 2/51
(96x96)	page 2/59
MB1-Serie (bargraphs)	page 2/61
M3-Serie (48x24)	page 2/63
PVE-Serie (72x36)	page 2/69
DVM (Voltage DC)	page 2/73
DAM (Current DC)	page 2/74
DMM (Current / Voltage DC)	page 2/75
DMM/DAM/DVM (Current / Voltage AC)	page 2/75
DAM/DVM (AC 1-Phase)	page 2/77
DAM/DVM (AC 3-Phase)	page 2/78
DFM (Frequency)	page 2/79
DTD (Temperature)	page 2/80

BCD | Serial | Bargraphs | Large-screen displays



DIGITAL PANEL INSTRUMENTS

DA08-NX_{xx}/X1_{xx} DA10-NX_{xx}/X1_{xx}



Digital panel instruments for standard signals DC, programmable

Digital displays for monitoring and control with different interfaces and inputs



- DC current/voltage (V/mA)
 - Voltage (mV)
 - Totalizing counter
 - LED-displays red or green
 - 3 - 5-digit displays
- DA08 = Digit height 7.62 mm
DA10 = Digit height 10.0 mm

DA08/DA10-NX_{xx}/X1_{xx}

Case 48 x 24 mm



DA08/DA10-NX_{xx}/X1_{xx}-7

Case 72 x 24 mm



DA08/DA10-NX_{xx}/X1_{xx}-4

Case 48 x 48 mm



Case - topview

front

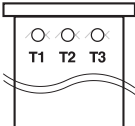

Technical Data

Type	DA08-NA _{xx} /E1 _{xx} DA10-NA _{xx} /E1 _{xx}	DA08-NA _{xx} /D1 _{xx} DA10-NA _{xx} /D1 _{xx}	DA08-NZ _{xx} /A1 _{xx} DA10-NZ _{xx} /A1 _{xx}
Input	Current/voltage 20mA/ 10V DC	Voltage mV	Totalizing counter
Panel cut-out (mm)			
DA08/DA10-NX _{xx} /X1 _{xx}	45(+0.6) x 22.2(+0.3) mm	45(+0.6) x 22.2(+0.3) mm	45(+0.6) x 22.2(+0.3) mm
DA08/DA10-NX _{xx} /X1 _{xx} -4	45(+0.6) x 45.0(+0.6) mm	45(+0.6) x 45.0(+0.6) mm	45(+0.6) x 45.0(+0.6) mm
DA08/DA10-NX _{xx} /X1 _{xx} -7	68(+0.7) x 22.2(+0.3) mm	68(+0.7) x 22.2(+0.3) mm	68(+0.7) x 22.2(+0.3) mm
Front frame height (mm)	5.25	5.25	5.25
Mounting depth (mm)	DA08-NA _{xx} /E1 _{xx} : 91 DA10-NA _{xx} /E1 _{xx} : 86 (79)	120	120
Operating elements	On the topside of case	On the topside of case	---
Auxiliary supply	18 - 35 V DC	18 - 35 V DC	18 - 35 V DC
Display/ digit height (mm) DA08	7.62	7.62	7.62
Display/ digit height (mm) DA10	10.0	10.0	10.0
LED-display colour	Red or green	Red or green	Red or green
Power consumption	Max. 1 VA	Max. 2.5 VA	max. 1.5 VA
Measuring range voltage	-10V ...+10V DC	0 - 60/150 mV DC	---
Measuring range current	-19mA ...+20mA DC	---	---
Measuring principle	Dual-Slope-integration	Dual-Slope-integration	---
Conversion rate	Approx.5 measurements/sec.	Approx.5 measurements/sec.	---
Measuring error	+/- 0.01%of measur.value +/- 1 digit	+/- 0.01%of measur.value +/- 1 digit	---
Overflow	Flashing of center segments	Flashing of center segments	---
Temperature range	-20°C ...+65°C	-20°C ...+65°C	-20°C ...+65°C
Signal and functional inputs			24V active high L < 7V / H > 10V
Counting input			Frequency max.1 kHz All segments are flashing (Independent of signal inputs)
ST segment test			Reset to 0 (Independent of signal inputs)
Reset			

Display messages

EEP	EEProm under programming
---	Overflow (Flashing of center segments)
⊕	Circuit break indicator (Below measured value)
Resolution	
DA08/DA10-NA ₃₀ /X1 _{xx} :	- 199 ...999
DA08/DA10-NA ₃₁ /X1 _{xx} :	- 1999 ...+1999
DA08/DA10-NA ₄₀ /X1 _{xx} :	- 1999 ...9999
DA08-NA ₄₁ /X1 _{xx} :	- 199 ...+19999
DA08-NA ₅₀ /X1 _{xx} :	- 19999 ...30000

Number of digits

DA08/DA10-NA ₃₀ /E1 _{xx} :	888
DA08/DA10-NA ₃₁ /E1 _{xx} :	± 1888
DA08/DA10-NA ₄₀ /E1 _{xx} :	8888
DA08-NA ₄₁ /E1 _{xx} :	± 18888
DA08-NA ₅₀ /E1 _{xx} :	88888
DA08/DA10-NZ ₃₀ /A1 _{xx} :	888
DA08/DA10-NZ ₄₀ /A1 _{xx} :	8888
DA08-NZ ₅₀ /A1 _{xx} :	88888

Pluggable screw terminal

DA08-NA_{xx}/E1_{xx} (Current/voltage)

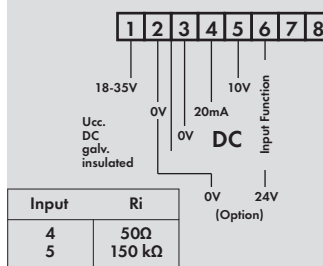

Pluggable screw terminal

DA08-NA_{xx}/D1_{xx} (Current/voltage)

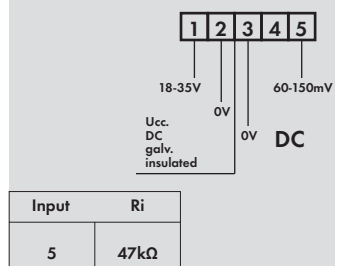

Ordering example

- 10 - Digit height 10mm
- A - Current and voltage
- 4 - 4 digits
- E - DC (20mA/10V)
- 1 - Ucc. 24 V DC
- F - Operating input
- G - Display colour green
- 7 - Case 72 x 24 mm

= DA10-NA40/E1FG-7

DA - N - 1 -

DA - NA - / E - - -

DA - NZ - / D - - -

- Case dimensions:
- Display colour:
- Option:
- Ucc.:
- Interface:
- Number of digit:
- Range:
- Digit height:

without indication = 48x24 mm	4 = 48x48 mm	7 = 72x24 mm
R = Red	G = Green	
O = None	F = Operating input	
1 = 24VDC		
E = DC Current/voltage 20mA/10V	D = DC voltage 60/150mV	A = Totalizing counter 24V
30 = 3-digit	31 = 3-1/2-digit	40 = 4-digit
41 = 4-1/2-digit	50 = 5-digit	
A = Current/voltage or voltage	Z = Counter	
08 = Digit height 7.62 mm	10 = Digit height 10.0 mm	

At DA08-NA/DA10-NA (voltage): Option not applied.

At DA08-NZ/DA10-NZ (summable counter): Displays only available 3-, 4- or 5-digit, Option not applied.

DA08-NSxx/X1x DA10-NSxx/X1x

Digital panel instruments for interface-control



Digital displays for monitoring and control with ProfiBus or serial interface



- ProfiBus L2DP
- Serial interface
- LED-displays red or green
- 3 - 5-digit displays

DA08 = Digit height 7.62 mm
DA10 = Digit height 10.0 mm



DA08/DA10-NSxx/X1x
Case 48 x 24 mm

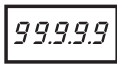

DA08/DA10-NSxx/X1x-7
Case 72 x 24 mm



DA08/DA10-NSxx/X1x-4
Case 48 x 48 mm



Case - topside front

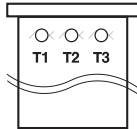

Technical Data

Type	DA08-NS50/P1x DA10-NS50/P1x	DA08-NSxx/X1x DA10-NSxx/X1x
Input	ProfiBus L2DP	Serial interface
Panel cut-out (mm)		
DA08/DA10-NSxx/X1x	45 (+0.6) x 22.2 (+0.3) mm	45 (+0.6) x 22.2 (+0.3) mm
DA08/DA10-NSxx/X1x-7	68 (+0.7) x 22.2 (+0.3) mm	68 (+0.7) x 22.2 (+0.3) mm
DA08/DA10-NSxx/X1x-4	45 (+0.6) x 45.0 (+0.6) mm	45 (+0.6) x 45.0 (+0.6) mm
Front frame height (mm)	5.25	5.25
Mounting depth (mm)	91	120
Auxiliary supply	18 - 35 V DC	18 - 35 V DC
Display/ digit height (mm) DA08	7.62	7.62
Display/ digit height (mm) DA10	10.0	10.0
LED-display colour	Red or green	Red or green
Power consumption	Max. 1.8 VA	Max. 1.5 VA
Temperature range	0°C ...+50°C	-20°C ...+65°C
Parallel connection	- - -	Max.32 devices
Baud rate (autom.recognition)	≤12M Baud	- - -
Address (0 ...127)	Adjustable on the top of case	- - -
Protocol	Profibus-DP	- - -
Hardware	SPC 3 Feldbus side galvanic insulated	- - -

Specification Profibus

Telegrams setup ASCII

Byte	Description	ASCII
1.	Digit 1 $\triangle 10^0$	3xH
2.	Digit 2 $\triangle 10^1$	3xH
3.	Digit 3 $\triangle 10^2$	3xH
4.	Digit 4 $\triangle 10^3$	3xH
5.	Digit 5 $\triangle 10^4$	3xH

Comma to be inserted anywhere

Telegram setup BCD

Byte	Function	Display
1.	10^0 10^0	0000,0
2.	10^1 10^1	00,00
3.	free 10^2	00,00
4.	free free	00,00
5.	free free	00,00
6.	free Comma	0,0000

Pluggable screw terminal for ProfiBus DA08/DA10-NS50/P1x

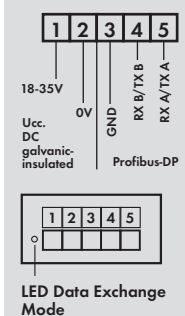

LED Data Exchange Mode

Specification serial interface

Pluggable screw terminal

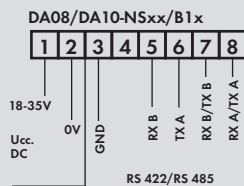
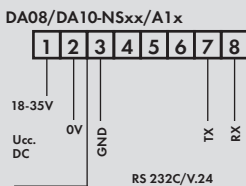

Telegram construction ASCII

Function	ASCII	Description
Segment test	\$0	Segment test on (up to the next telegram)
Leading zeros	\$1	Indication of leading zeros
Flashing sign	\$3"28"	"28" is flashing
Flashing display	\$4	Flashing on
	\$5	Flashing off
Direction of writing	\$6	Left → Right
	\$7	Right → Left

Number of digits serial interface

DA08/DA10-NS30/X1x:	888
DA08/DA10-NS40/X1x:	8888
DA08-NS50/X1x:	88888

Sign rate

Hex	20	2C	2D	2E	30	31	32	33	34	35	36	37	38	39	3D	41	43	45	46	48	4C	50	55	5D	5F	62	63	64	68	6E	6F	72	75	78	7E
Digit	0	1	2	3	4	5	6	7	8	9	=	[E	F	K	L	P	U] B	C	D	H	N	O	R	V	0	+	=		

unknown sign

Ordering example

- 08 - Digit height 7.62 mm
- NS - ProfiBus or serial
- 50 - Display with 5 digit
- P - ProfiBus
- 1 - Ucc. 24 V DC
- R - Display colour red
- 4 - Case 48 x 48 mm

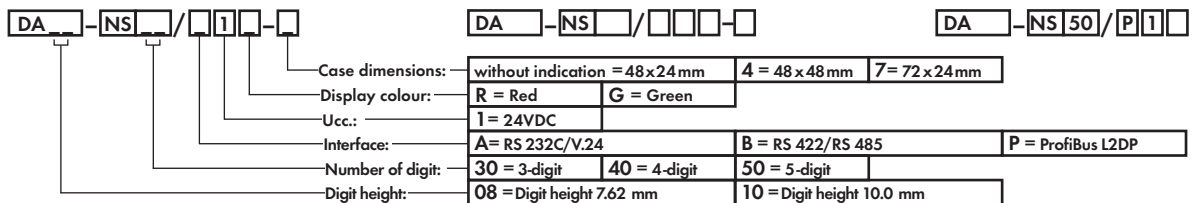

= DA08-NS50/P1R-4

At DA08-NS50/DA10-NS50 (Profibus): Display only available with 5-digits

DA12-NA40/X1xx

Digital panel meter for standard signals AC, programmable



Digital displays for monitoring and control with different interfaces and inputs



- AC current/voltage
- Frequency
- Driving speed
- Rpm
- 4-digit displays
- LED-display red or green

DA12 = Digit height 14.0 mm

DA12-NA40/X10x

Case 72 x 24 mm



DA12-NA40/X10x-3

Case 72 x 36 mm



DA12-NA40/X10x-4

Case 72 x 48 mm

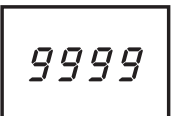

DA12-NA40/X10x-7

Case 72 x 72 mm



Technical Data		
Type	DA12-NA40/F1xx	DA12-NA40/I1xx
Input	AC current/voltage V/A	Frequency/driving speed
Panel cut-out (mm)	DA12-NA40/X1xx 68(+0.7) x 22.2(+0.3) mm DA12-NA40/X1xx-3 68(+0.7) x 33.0(+0.6) mm DA12-NA40/X1xx-4 68(+0.7) x 45.0(+0.6) mm DA12-NA40/X1xx-7 68(+0.7) x 68.0(+0.7) mm	68(+0.7) x 22.2(+0.3) mm 68(+0.7) x 33.0(+0.6) mm 68(+0.7) x 45.0(+0.6) mm 68(+0.7) x 68.0(+0.7) mm
Front frame height (mm)	5.25	5.25
Mounting depth (mm)	110	110
Display/digit height (mm)	14.0	14.0
LED-display colour	Red or green	Red or green
Auxiliary supply	18 - 35 V DC	18 - 35 V DC
Power consumption	Max. 2.5 VA	Max. 2.5 VA
Measuring ranges voltage	2V/100V/250V/500V DC	---
Measuring ranges current	3A/6A AC	---
Display max.	Free programmable	Free programmable
Display zero	Free programmable	Free programmable
Conversion rate	Approx. 1 measurement/1 sec.	1 ... 19 sec. programmable
Measuring principle	Dual-Slope-integr., True RMS	---
Measuring error	+/-0.2% of measuring value +/-1 digit/segment	+/-0.01% of measuring value +/-1 digit/segment
Overflow	Flashing of display segments in the middle	Flashing of display segments in the middle
Average value	Adjustable from 1-999 measur.	Adjustable from 1-500 measur.
Frequency range	20 Hz - 20 kHz	0.05 ... 9.999 kHz
Input resistance	Clamp Ri	
	1 10 kΩ	
	2 470 kΩ	
	3 1 MΩ	
	4 2.2 MΩ	
	6 0.02 Ω	
	7 0.01 Ω	
Resolution	0 ... 9999	0 ... 9999

Display messages	
EEP	EEProm under programming
----	Overflow (Flashing of display segments in middle)
⊕	Line break indicator (below measured value)

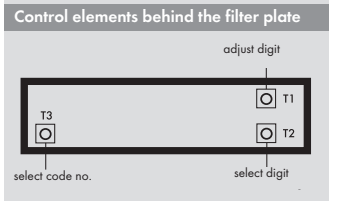
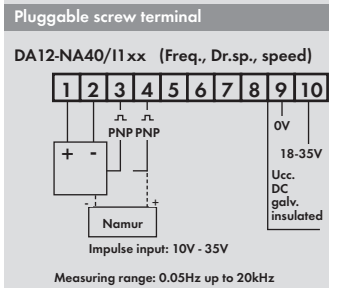
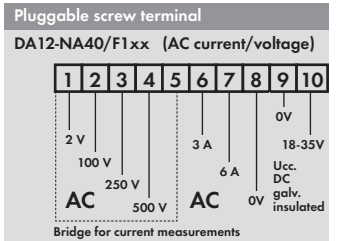

Ordering example

DA12-NA40/...

- A - Frequency measurement
- 1 - Ucc. 24 V DC
- G - Display colour green
- 4 - Case 72 x 72 mm

= DA12-NA40/I10G-7

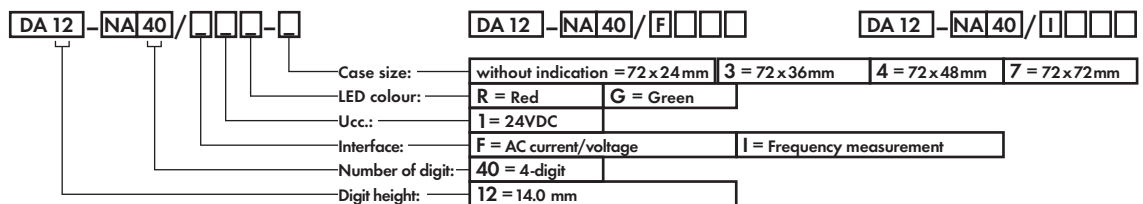

DA12-NA40: Display only available with 4-digits

DA13-NAxx/Xxxx

Digital panel instruments for standard signals DC, programmable



Digital displays for monitoring and control with different interfaces and inputs



- DC current/voltage (V/mA)
 - Connection to shunt (mV/mA)
 - LED-display red or green
 - Up to 5-digit display
- DA13 = Digit height 14.0 mm**

DA13-NA40/X10x

Case 96 x 24 mm



DA13-NA40/X10x-4

Case 96 x 48 mm



DA13-NA40/X10x-9

Case 96 x 96 mm

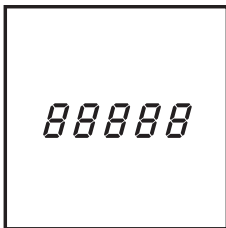

Technical Data

Type	DA13-NAxx/Axxx	DA13-NAxx/Dxxx
Input	DC current/voltage V/mA	DC current/voltage mV/mA
Panel cut-out (mm)		
DA13-NAxx/Xxxx	92(+0.8) x 22.2(+0.6) mm	92(+0.8) x 22.2(+0.6) mm
DA13-NAxx/Xxxx-4	92(+0.8) x 45.0(+0.6) mm	92(+0.8) x 45.0(+0.6) mm
DA13-NAxx/Xxxx-9	92(+0.8) x 92.0(+0.8) mm	92(+0.8) x 92.0(+0.8) mm
Front frame height (mm)	7.5	7.5
Mounting depth (mm)	110	110
Display/digit height (mm)	14.0	14.0
LED-display colour	Red or green	Red or green
Auxiliary supply		
DA13-NAxx/A1xx	18 - 35 V DC	18 - 35 V DC
DA13-NAxx/A2xx	115/230V AC	115/230V AC
Power consumption	Max. 3 VA	Max. 3 VA
Measuring ranges voltage	2V/10V/40V/200V DC	60mV/125mV/150mV/300mV
Measuring ranges current	20mA/200mA	0.1mA/1mA DC
Display max.	Free programmable	Free programmable
Display zero	Free programmable	Free programmable
Conversion rate	Approx. 1 measurement/1sec.	Approx. 1 measurement/1sec.
Measuring principle	Dual-Slope-integration	Dual-Slope-integration
Measurin error	+/-0.01% of measuring value +/-1 digit/segment	+/-0.01% of measuring value +/-1 digit/segment
Overflow	Flashing of display segments	Flashing of display segments
Average value	Adjustable from 1-500 measur.	Adjustable from 1-500 measur.

Display messages

EPP	EEProm under programming
---	Overflow (Flashing of center segments)
⊕	Line break indicatipon with value failing (Below measured value)

Number of digits

DA13-NA30/Xxxx	888
DA13-NA30/Xxxx	± 8888
DA13-NA40/Xxxx	8888
DA13-NA41/Xxxx	± 18888
DA13-NA50/Xxxx	88888

Resolution

..NA30..	-199	... 999
..NA31..	-1999	...+1999
..NA40	-1999	... 9999
..NA41..	-19999	...+19999
..NA50..	-19999	... 30000

Control elements behind the filter plate

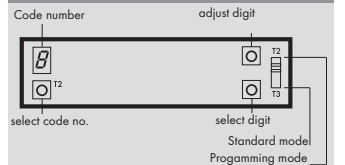

Input resistance	Clamp	Ri	Overload contin.	Overload 3sec.
DA13-NAxx/Axx	1	100 kΩ	50 V	---
	2	560 kΩ	100 V	---
	3	2.2 MΩ	500 V	---
	4	12 MΩ	1000 V	---
	6	100 Ω	70 mA	140 mA
	7	10 Ω	250 mA	500 mA
	Input resistance	Clamp	Ri	
DA13-NAxx/Dxx	1	100 kΩ		
	2	220 kΩ		
	3	270 kΩ		
	4	560 kΩ		
	6	560 Ω		
	7	68 Ω		

Pluggable screw terminal

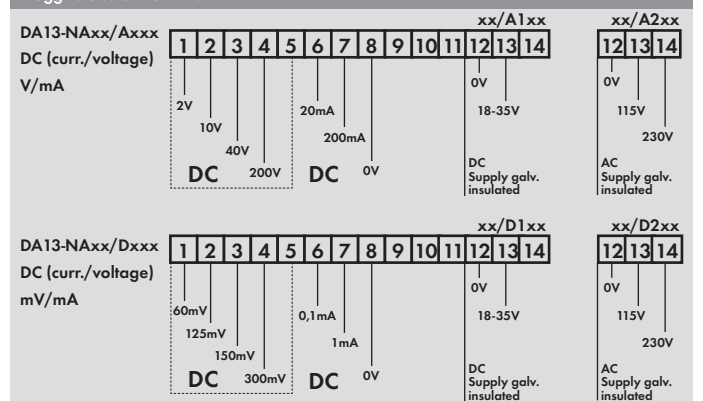

Ordering example

DA13-NA...

- 31 - Figures 3- 1/2-digit
- A - DC current/voltage
- 2 - Ucc. 115/230V AC
- G - Display colour green
- 9 - Case 96 x 96 mm

= DA13-NA31/A20G-9

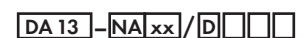
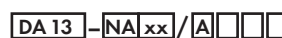

Case size:	without indication = 96 x 24 mm	4 = 96 x 48 mm	9 = 96 x 96 mm
LED colour:	R = Red	G = Green	
Option:	See page 2/9 and 2/10		
Ucc.:	1 = 24V DC	2 = 115/230V AC	
Interface:	A = DC current/voltage	D = DC mV/mA	
Number of digit:	30 = 3-digit	31 = 3-1/2-digit	40 = 4-digit 41 = 4-1/2-digit 50 = 5-digit
Digit height:	13 = 14.0 mm		

DA13-NA31/Mxxx



Digital panel instruments for temperature measurement PT100

Digital display for monitoring and control



- PT100 temperature
- 3 1/2-digit display
- LED-display red or green

DA13 = Digit height 14.0 mm

DA13-NA31/Mxxx Case 96 x 24 mm



DA13-NA31/Mxxx-4 Case 96 x 48 mm



DA13-NA31/Mxxx-9 Case 96 x 96 mm



Technical Data

Type	DA13-NA31/Mxxx
Input	PT100 temperature
Panel cut-out (mm)	
DA13-NA31/Xxxx	92(+0.8) x 22.2(+0.6) mm
DA13-NA31/Xxxx-4	92(+0.8) x 45.0(+0.6) mm
DA13-NA31/Xxxx-9	92(+0.8) x 92.0(+0.8) mm
Front frame height (mm)	7.5
Mounting depth (mm)	110
Display/digit height (mm)	14.0
LED-display colour	Red or green
Auxiliary supply	
DA13-NAxx/M1xx	18 - 35 V DC
DA13-NAxx/M2xx	115/230 V AC
Power consumption	max. 3 VA
Measuring ranges PT100	-100.0 up to 199.9°C -200.0 up to 800.0°C -100.0 up to 199.9°F -200.0 up to 1472°F
Conversion rate	Approx. 1 measurement/1 sec.
Measuring principle	Dual-Slope-integration
Measuring error	+/-0.02% of measuring value +/-1 digit/segment
Overflow	Flashing of display segments
Resolution	+/- 1K(PT100 200°C:+/- 0.1K)

Pluggable screw terminal

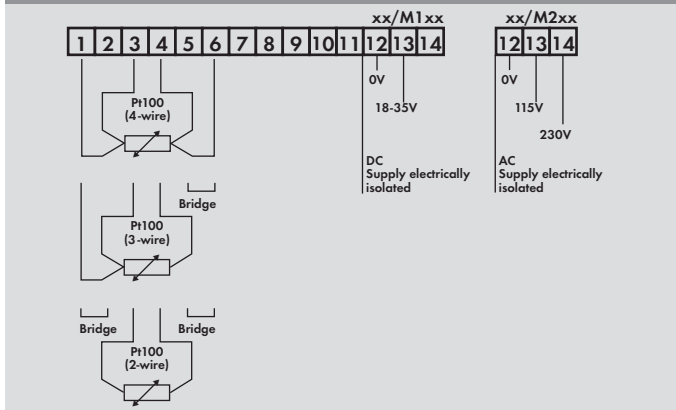

Control elements behind the filter plate

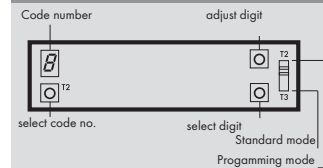

Ordering example

DA13-NA...

- 40 - Figures 5 digit
- 1 - Driving speed
- 2 - Ucc. 115/230V AC
- G - Display colour red
- 9 - Case 96 x 96 mm

= DA13-NA40/I20G-9

DA 13 - NA 31 / M [] [] [] [] []

DA 13 - NA 31 / M [] [] [] [] []

Case size:	without indication = 96 x 24 mm	4 = 96 x 48 mm	9 = 96 x 96 mm
LED colour:	R = Red	G = Green	
Option:	See page 2/9 and 2/10		
Ucc.:	1 = 24V DC	2 = 115/230V AC	
Interface:	M = PT100 temperature		
Number of digit:	31 = 3 1/2-digit		
Digit height:	13 = 14.0 mm		

DA13-NA31/Mxxx: Display only available with 3 1/2-digits

Options: for DA13-NA

Valid for:

DA13-NA__/A__
DA13-NA__/D__
DA13-NA__/G__
DA13-NA__/F__

DA13-NA__/I__
DA13-NA__/L__
DA13-NA__/M__

Option: 1

Analogue output 0 - 10V DC

Option: 4

Analogue output 0 - 10V DC, electrically insulated to measuring

connection

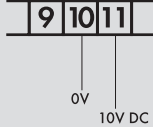

Max.+min. values of analogue output depend on min.+max measurements values under code number 1 + 3

Programming

only for: DA13-NA__/L__
DA13-NA__/M__

Code	Display	Description
3	---	Temperature + analogue output min.value
4	---	Temperature + analogue output max.value

Option: 2

Analogue output 0/4 - 20 mA DC

connection

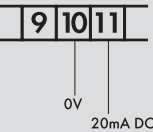

Max.+min. values of analogue output depend on min.+max measurements values under code number 1 + 3

Programming

only for: DA13-NA__/L__
DA13-NA__/M__

Code	Display	Description
3	---	Temperature + analogue output min.value
4	---	Temperature + analogue output max.value
6	1--	Analogue output DC 0=0-20mA 1=4-20mA

Option: 7

1 Alarm contact open collector

connection

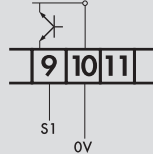

12 Watt max.
max. 30 V (0.5A)

Programming

Code	Display	Description
7	S1	Upper switching threshold
8	S1	Lower switching threshold
9	--1	0=inactive 1=active
	0	Operating current Max-contact
	1	Quiescent current Max-contact
	2	Operating current Min-contact
0	_3_	Quiescent current Min-contact
	0--	Display normal if S1 ative
1	1--	Display is flashing if S1 active

Option: 8

2 Alarm contacts open collector

connection

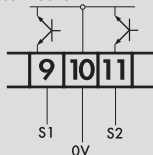

12 Watt max.
max. 30 V (0.5A)

Code	Display	Description
7	S1	Upper switching threshold
8	S1	Lower switching threshold
9	--1	0=inactive 1=active
	0	Operating current Max-contact
	1	Quiescent current Max-contact
	2	Operating current Min-contact
0	_3_	Quiescent current Min-contact
	0--	Display normal if S1 ative
1	1--	Display is flashing if S1 active

Programming

Code	Display	Description
A	S2	Upper switching threshold
B	S2	Lower switching threshold
C	--1	0=inactive 1=active
	0	Operating current Max-contact
	1	Quiescent current Max-contact
	2	Operating current Min-contact
0	_3_	Quiescent current Min-contact
	0--	Display normal if S2 ative
1	1--	Display is flashing if S2 active

Option: D

Input for display blank

connection

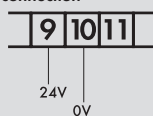

Input:	Active-high, 24V
L-signal:	Display shows present measurement value
H-signal:	Display blank

Option: G

Input segment test

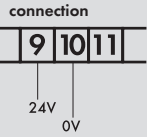

Input:	Active-high, 24V
L-signal:	Display shows present measurement value
H-signal:	All segments and decimal points light

Option: H

Display Hold

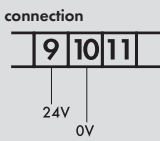

Input:	Active-high, 24V
L-signal:	Display shows present measurement value
H-signal:	Display stores measurement value

Option: R

2 Relais contacts

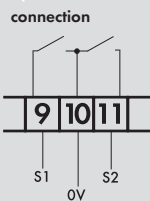

10 Watt max.
max. 200V (0.05A)
max. 0.5A (20V)

Code	Display	Description
7	S1	Upper switching threshold
8	S1	Lower switching threshold
9	--1	0= inactive 1=active
	--0	Operating current Max-contact
	--1	Quiescent current Max-contact
	--2	Operating current Min-contact
0	0--	Display normal if S1 ative
	1--	Display is flashing if S1 active

Programming

Code	Display	Description
A	S2	Upper switching threshold
b	S2	Lower switching threshold
C	--1	0= inactive 1=active
	--0	Operating current Max-contact
	--1	Quiescent current Max-contact
	--2	Operating current Min-contact
0	0--	Display normal if S2 ative
	1--	Display is flashing if S2 active

Option: R

Serial output RS232

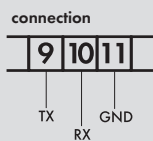

Code	Display	Description
7	--0	0= 150 Baud 4= 150 Baud
	---	1= 300 Baud 5= 4800 Baud
	---	2= 600 Baud 6= 9600 Baud
	---	3= 1200 Baud 7= 19200 Baud
	--0	0= without parity 8 data bits
	---	1= party even 7 data bits
	---	2= party odd 7 data bits
	---	3= party even 8 data bits
8	---	4= party odd 8 data bits
	---	address of display unit
	--00	no address
	--X	address 10 ⁰
--X	address 10 ¹	

Programming

Code	Display	Description
9	--X	Direction of writing 0= left 1= right
	--0	0= Serial output off
	---	1= digit sign/ value
	---	2= STX/ sign/ value/ ETX
	---	3= STX/ adr./ sign/ value/ ETX
	---	4= SOH/ adr./ STX/ sign/ value/ ETX
	---	Transfer instruction
	0--	off
	1--	Transfer after received address
	2--	Transfer after STX/ adr./ ETX received

Option: S

Min.- Max.- Memory

The buttons T1- T3 are inserted through a filter plate. By activating the T1 longer than 5 seconds a reference measurement is effected. If T1 is activated for a duration of fewer than 5 seconds the up to now saved min.-max.-values are deleted. The value of reference measurement is maintained. Afterwards by T2 (max.-value) and T3 (min.-value) the respective extreme value can be recalled with regard to the reference measurement.

DIGITAL PANEL INSTRUMENTS

DA13-NS_{xx}/xxx



Digital panel instruments for serial control

Digital displays for monitoring and control with serial interface



- Serial
- LED-display red or green
- 2 - 6-digit displays

DA13 = Digit height 14.0 mm

DA13-NS40/Xxx
Case 72 x 24 mm



DA13-NS40/Xxx-4
Case 72 x 48 mm

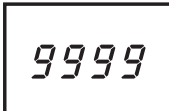

DA13-NS40/Xxx-9
Case 72 x 72 mm



Without illus. (6-digit display)
DA13-NS60/Xxx = 96x24mm
DA13-NS60/Xxx-4 = 96x48mm
DA13-NS60/Xxx-9 = 96x96mm

Technical Data

Type	DA13-NS40/Xxx - DA13-NS60/Xxx
Input	Serial
Panel cut-out (mm)	
DA13-NS20 /-NS30 /-NS40	68(+0.7) x 22.2(+0.3) mm
DA13-NS50 /-NS60	92(+0.8) x 22.2(+0.6) mm
DA13-NS20- /-NS30- /-NS40/Xxx-4	68(+0.7) x 45.0(+0.6) mm
DA13-NS50- /-60/Xxx-4	92(+0.8) x 45.0(+0.6) mm
DA13-NS20- /-NS30- /-NS40/Xxx-9	68(+0.7) x 68.0(+0.7) mm
DA13-NS50- /-60/Xxx-9	92(+0.8) x 92.0(+0.8) mm
Front frame height (mm)	
DA13-NS20/Xxx - DA13-NS40/Xxx	5.2
DA13-NS50/Xxx - DA13-NS60/Xxx	7.5
Installation depth (mm)	104
Auxiliary supply	18 - 35 V DC
Display/digit height (mm)	14.0
LED-display colour	Red or green
Power consumption	Max. 2.5 VA
Temperature range	-20°C ... +65°C

Number of digits	
DA13-NS20/Xxx	88
DA13-NS30/Xxx	888
DA13-NS40/Xxx	8888
DA13-NS50/Xxx	88888
DA13-NS60/Xxx	888888

BCD-switch	
01...98	Fading out from up to 98 leading signs
99	Self test

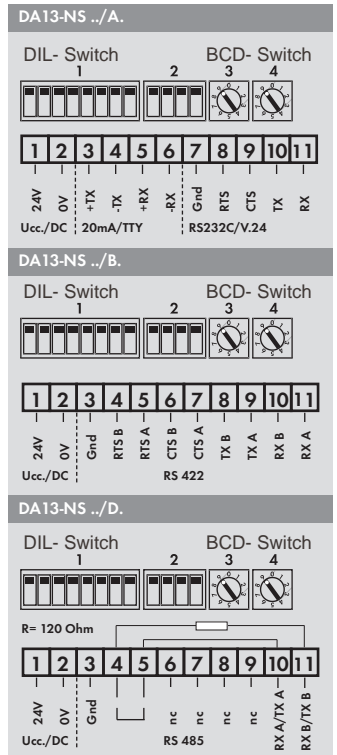

DIL-switch 1			
1.1	1.2	Baud rate	1.5
off	off	1200 Baud	on Parity even
on	off	2400 Baud	off Parity odd
off	on	4800 Baud	1.6
on	on	9600 Baud	on STX/ ETX
			off CR/ LF
1.3			1.7 Direction of writing
on		8 data bits	on left > right
off		7 data bits	off right > left
1.4			1.8
on		with parity bit	on 20mA/TTY
off		without parity bit	off RS232C/V.24

DIL-switch 2			
2.1	Leading zeros		
on	Parity even		
off	Parity odd		
2.2	2.3	2.4	Addresses
off	off	off	without
on	off	off	1.device
off	on	off	2.device
on	on	off	3.device
off	off	on	4.device
on	off	on	5.device
off	on	on	6.device
on	on	on	7.device

Telegram construction ASCII		
Function	ASCII	Description
Segment test	\$0	Segment test on (up to th next telegram)
Leading zeros	\$1	Indication of leading zeros
	\$2	Fading out of leading zeros
Flashing sign	\$3"28"	"28" is flashing
Flashing display	\$4	Flashing on
	\$5	Flashing off
Direction of writing	\$6	left → right
	\$7	right → left

Sign rate	Hex	20	2D	2C	2E	30	31	32	33	34	35	36	37	38	39	3D	41	43	45	46	48	4C	50	55	5D	5F	62	63	64	68	6E	6F	72	75	78	7E	unknown sign
Digit		,	.	0	1	2	3	4	5	6	7	8	9	=	R	[E	F	K	L	P	U]	B	C	D	H	N	O	R	V	0	+	=			

Ordering example

- 13 - Digit height 14.0 mm
- NS - ProfiBus or serial
- 60 - Display with 6 digits
- B - RS 422 interface
- 1 - Ucc. 18-35 V DC
- R - Display colour red
- 4 - Case 96 x 48 mm

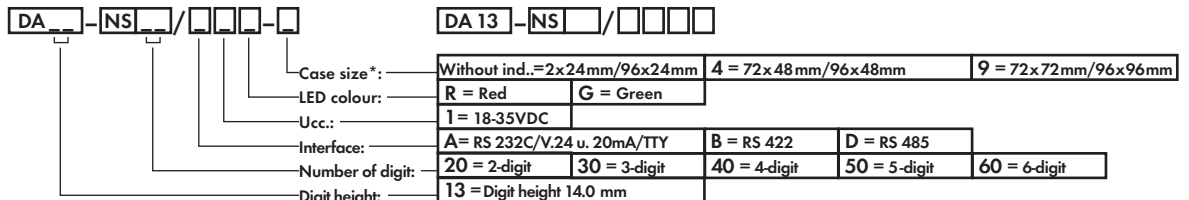

* Listed case size : From NS20 up to NS40/NS60

DA13-NSxx/Pxx

Digital panel instruments for ProfiBus L2DP control

Digital displays for monitoring and control with ProfiBus interface



- ProfiBus L2DP
- LED-displays red or green
- 4 or 6-digit display

DA13 = Digit height 14.0 mm



DA13-NS40/P1x Case 72 x 24 mm



DA13-NS60/P1x Case 96 x 24 mm



Case - topview
front

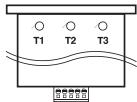

Back view

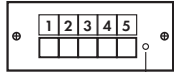

LED
Data Exchange Mode

Option: with Sub-D female connector available.

Technical Data

Type	DA13-NS40/P1x - DA13-NS60/P1x
Input	ProfiBus L2DP
Panel cut-out (mm)	
DA13-NS40/P1x	68 (+0.7) x 22.2 (+0.3) mm
DA13-NS60/P1x	92 (+0.8) x 22.2 (+0.6) mm
Front frame height (mm)	
DA13-NS40/P1x	5.2
DA13-NS60/P1x	7.5
Installation depth (mm)	91
Auxiliary supply	18 - 35 V DC
Display/digit height (mm)	14.0
LED-display colour	Red or green
Power consumption	Max. 2.5 VA
Temperature range	0°C ... +50°C
Baud rate (autom.recognition)	≤ 12M Baud
Address (0 ...127)	Adjustable at the topside of case
Protocol	ProfiBus-DP
Hardware	SPC 3 field bus site galvanic insulated

Telegram construction ASCII

Byte	Description	ASCII
1.	Digit 1 $\triangle 10^0$	3xH
2.	Digit 2 $\triangle 10^1$	3xH
3.	Digit 3 $\triangle 10^2$	3xH
4.	Digit 4 $\triangle 10^3$	3xH
5.	Digit 5 $\triangle 10^4$	3xH
6.	Digit 5 $\triangle 10^5$	3xH
7.		
8.	free	

Add comma at any place.

Telegram construction BCD

Byte	Function	
1.	10^1	10^0
2.	10^3	10^2
3.	free	10^4
4.	free	free
5.	free	free
6.	free	free
7.	free	free
8.	free	Comma Display

0 0 0 0 1 0 0000.0
0 0 1 1 0 0000.00
0 0 1 1 1 000.000
0 1 1 0 0 00.0000
0 1 1 0 1 0.00000

Pluggable screw terminal for ProfiBus

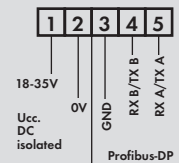

Sign rate

Hex	20	2D	2E	30	31	32	33	34	35	36	37	38	39	3D	41	43	45	46	48	4C	50	55	5D	5F	62	63	64	68	6E	6F	72	75	78	7E	unknown sign
Digit	.	.	.	0	1	2	3	4	5	6	7	8	9	=	R	[E	F	K	L	P	U]		B	C	D	H	N	O	R	V	0	+	=

Ordering example

- 13 - Digit height 14.0 mm
- NS - ProfiBus or serial
- 40 - Display with 4 digits
- P - ProfiBus
- 1 - Ucc. 24 V DC
- G - Display colour red

= DA13-NS40/P1G
(The case sizes is the result of the 4-digit display = 72 x 24mm)

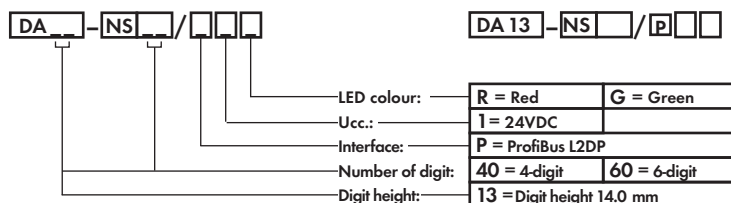

DBA-EA13/A DBA-EA20/A

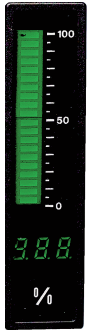

Digital bargraph for standard signals, programmable

Digital panel bargraph for monitoring and control with different interfaces and inputs

- DC current/voltage (V/mA)
- Bargraph & digital display
- LED-displays red or green

Case 72 x 24 mm

Scale length 25/50 mm

DBA-EA13/AxxxH

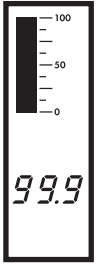

DBA-EA20/AxxxT



Control elements behind filter plate

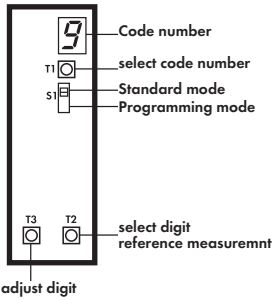

DBA-EA13/AxxxQ



Controls behind front glass

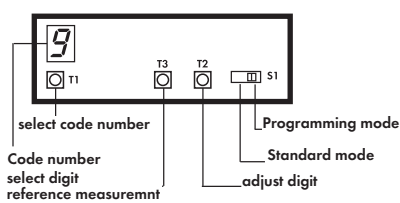

DBA-EA20/AxxxQ

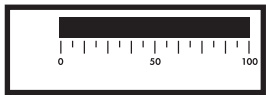

Pluggable screw terminal

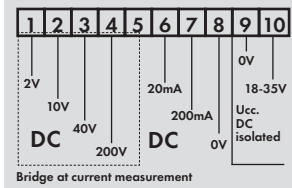

Display messages

EEP	EEProm under programming	
----	Overflow (Flashing of center segments)	
-	Line break indicator (Below measured value)	

Ordering example

DBA-EA...
 A - DC current/voltage
 20 - 20 segments
 1 - Ucc. 24 V DC
 0 - Option
 R - Display colour red
 Q - Horizontal format
 = DBA-EA20/A10RQ

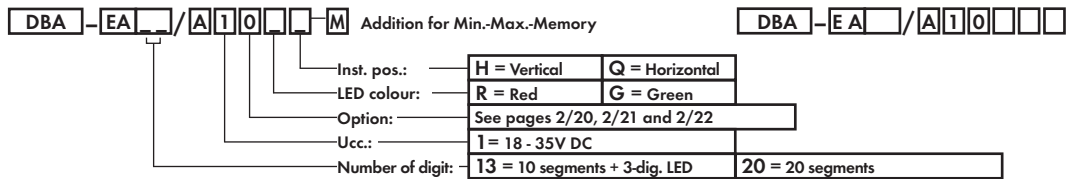

Technical Data

Type	DBA-EA13/A	DBA-EA20/A
Input	DC current/voltage V/mA	DC current/voltage V/mA
Panel cut-out (mm)	68(+0.7) x 22.2(+0.3) mm	68(+0.7) x 22.2(+0.3) mm
Front frame height (mm)	5.5	5.5
Mounting depth (mm)	115	115
Display/digit height (mm)	7 mm/ 3-digit	7 mm/ 3-digit
Scale length	25 mm/ 10 segments	50 mm/ 20 segments
Resolution measuring range	-99 ...999	-99 ...999
Resolution scale	1 segment	1 segment
	Final value of scale refers to the incoming Display max.	
LED-display colour	Red or green	Red or green
Option	Min.- Max.- Memory	Min.- Max.- Memory
Auxiliary supply	18 - 35 V DC	18 - 35 V DC
Power consumption	Max. 2.5 VA	max.2.5 VA
Measuring ranges voltage	2V/10V/40V/200V DC	2V/10V/40V/200V DC
Measuring ranges current	20mA/200mA DC	20mA/200mA DC
Display max.	Free programmable	Free programmable
Display zero	Free programmable	Free programmable
Conversion rate	Approx. 1 measurement/1sec.	Approx. 1 measurement/1sec.
Measuring principle	Dual-Slope-integration	Dual-Slope-integration
Measuring error	+/-0.01% of measuring value +/-1 digit/segment	+/-0.01% of measuring value +/-1 digit/segment
Overflow	Flashing of tcenter segments and of every 2nd scale segment	Flashing of tcenter segments and of every 2nd scale segment
Average value	Adjustable from 1-500 measur.	Adjustable from 1-500 measur.
Input resistance	Clamp Ri	Clamp Ri
	1 100 kΩ	1 100 kΩ
	2 580 kΩ	2 580 kΩ
	3 2.2 MΩ	3 2.2 MΩ
	4 10 MΩ	4 10 MΩ
	6 100 Ω	6 100 Ω
	7 10 Ω	7 10 Ω

DBA-EA23/F DBA-EA23/M

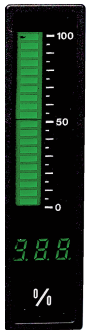

Digital bargraph for alternating current or voltage and temperature, programmable

Digital panel bargraph for monitoring and control with different interfaces and inputs

- AC current/voltage
- Temperature
- Bargraph and digital panel
- LED-displays red or green

Case 96 x 24 mm

Scale length 50 mm

DBA-EA23/XxxxH

Control elements behind the filter plate

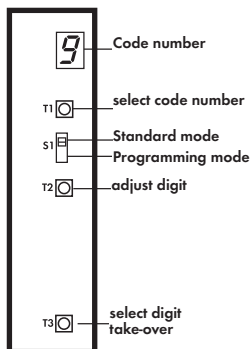

DBA-EA23/XxxxQ



Control elements behind the filter plate

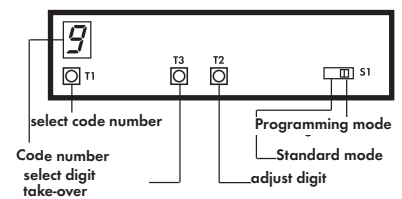

Technical Data

Type	DBA-EA23/F	DBA-EA23/M
Input	AC current/voltage	Temperature
Panel cut-out (mm)	92(+0.8) x 22.2(+0.6) mm	92(+0.8) x 22.2(+0.3) mm
Front frame height (mm)	7.5	7.5
Mounting depth (mm)	115	115
Display/digit height (mm)	7 mm/ 3-digit	7 mm/ 3-digit
Scale length	50 mm/ 10 segments	50 mm/ 20 segments
Resolution measuring range	-99 ...999	-99 ...999
Resolution scale	1 segment	1 segment
	Final value of scale refers to the incoming indication final value	
LED-display colour	Red or green	Red or green
Option	Min.- Max.- Memory	Min.- Max.- Memory
Auxiliary supply		
DBA-EA.../F1 DBA-EA.../M1	18 - 35 V DC	18 - 35 V DC
DBA-EA.../F2 DBA-EA.../M2	115/230V AC	115/230V AC
Power consumption	Max. 2.5 VA	Max.2.5 VA
Measuring ranges voltage	2V/10V/40V/200V DC	---
Measuring ranges current	3A/6A AC	---
Measuring ranges PT100	---	-19.9 up to 99.9 °C -199 up to 800 °C -19.9 up to 99.9 °F -199 up to 999 °F
Display max.	Free programmable	---
Display zero	Free programmable	---
Conversion rate	Approx. 1 measurement/1 sec.	approx. 1 measurement/1 sec.
Measuring principle	Dual-Slope-integration, True RMS	Dual-Slope-integration
Measuring error	+/-0.2% of measuring value +/-1 digit/segment	+/-1K[PT100 200°C: +0.1K +/-1 digit/segment
Overflow	Flashing of center segments and of every 2nd scale segment	Flashing of the middle segments and of every 2nd scale segment
Average value	Adjustable from 1-500 measur.	---

Pluggable screw terminal

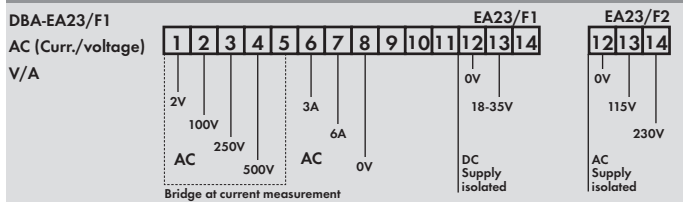

Pluggable screw terminal

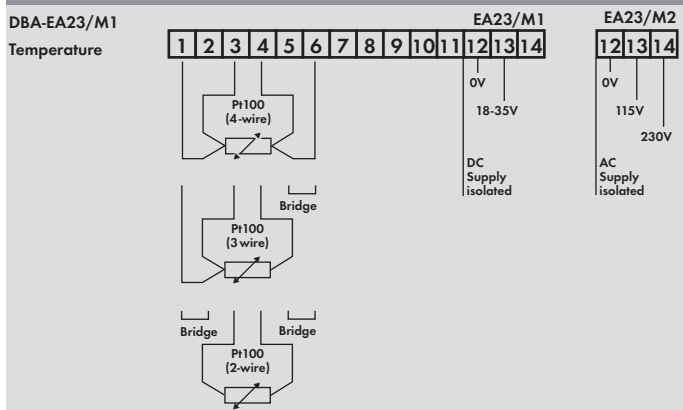

Display messages

- EEP EEprom under programming
- Overflow (Flashing of display segm. in th. middle)
- +| Line break indicator (Below measured value)

Input resistance EA23/F	Clamp	Ri
	1	10 kΩ
	2	470 kΩ
	3	1 MΩ
	4	2.2 MΩ
	6	0.02 Ω
	7	0.01 Ω

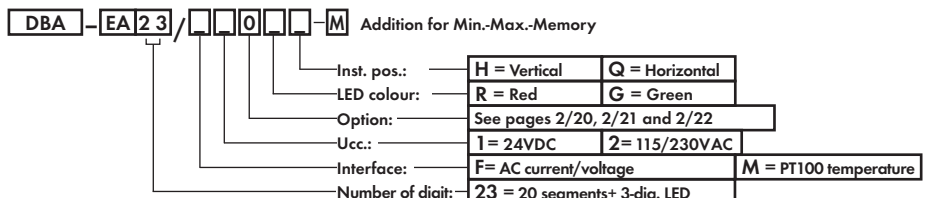

DBA-EA30/A DBA-EA30/D

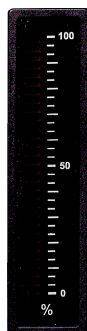

Digital bargraph for standard signals, programmable

Digital panel bargraph for monitoring and control with different interfaces and inputs

- DC current/voltage (V/mA)
- Connection to shunt (mV/mA)
- LED-displays red or green

Case 96 x 24 mm

Scale length 75 mm



DBA-EA30/XxxxH

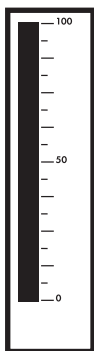

Control elements behind the filter plate

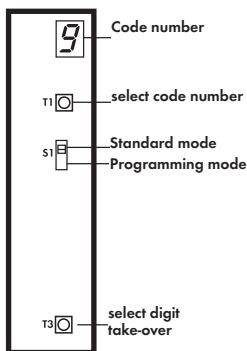

DBA-EA30/XxxxQ

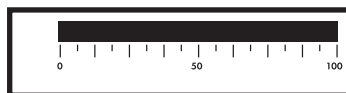

Control elements behind the filter plate

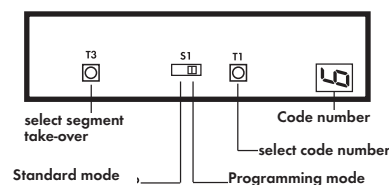

Display messages

EEP	EEProm under programming	■■■■■■■■■■
----	Overflow (Flashing of display segm. in th. middle)	■■■■■ ■■■■
┆┆	Line break indicator (Below measured value)	■■■■■■■■■■

Pluggable screw terminal

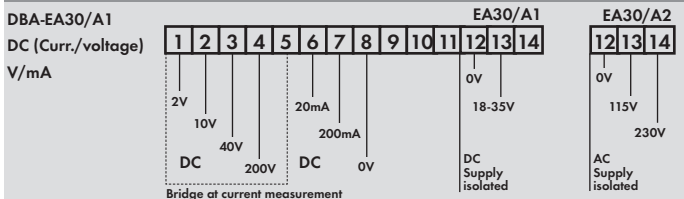

Pluggable screw terminal

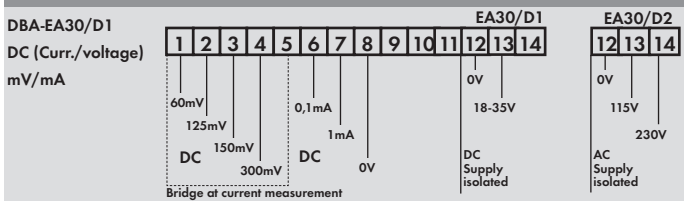

Ordering example

DBA-EA30/...

- D - DC current/voltage mV/mA
- 2 - Ucc. 115/230 V AC
- 0 - Option
- R - Display colour red
- Q - Horizontal format

= DBA-EA30/D20RQ

DBA - EA 30 / [] [] [] [] - M Addition for Min.-Max.-Memory

Inst. pos.:	H = Vertical	Q = Horizontal
LED colour:	R = Red	G = Green
Option:	See pages 2/20, 2/21 and 2/22	
Ucc.:	1 = 24V DC	2 = 115/230V AC
Interface:	A = DC current/voltage	D = DC current/voltage mV/mA
Number of digits:	30 = 30 segments	

Technical Data

Type	DBA-EA30/A	DBA-EA30/D
Input	DC current/voltage V/mA	DC current/voltage mV/mA
Panel cut-out (mm)	92(+0.8) x 22.2(+0.3) mm	92(+0.8) x 22.2(+0.6) mm
Front frame height (mm)	7.5	7.5
Mounting depth (mm)	120	115
Display/digit height (mm)	- - -	- - -
Scale length	75 mm/ 30 segments	75 mm/ 30 segments
Resolution measuring range	- - -	- - -
Resolution scale	1 segment	1 segment
	Final value of scale refers to the incoming indication final value	
LED-display colour	Red or green	Red or green
Option	Min.- Max.- Memory	Min.- Max.- Memory
Auxiliary supply		
DBA-EA.../A1 DBA-EA.../D1	18 - 35 V DC	18 - 35 V DC
DBA-EA.../A2 DBA-EA.../D2	115/230V AC	115/230V AC
Power consumption	Max. 2.5 VA	max.2.5 VA
Measuring ranges voltage	2V/10V/40V/200V DC	60mV/125mV/150mV/300mV
Measuring ranges current	20mA/200mA DC	0.1mA/ 1mA DC
Display max.	Free programmable	Free programmable
Display zero	Free programmable	Free programmable
Conversion rate	Approx. 1 measurement/1sec.	Approx. 1 measurement/1sec.
Measuring principle	Dual-Slope-integration	Dual-Slope-integration
Measuring error	+/-0.01% of measuring value +/- 1 digit/segment	+/-0.01% of measuring value +/- 1 digit/segment
Overflow	Flashing of every 2nd scale segment	Flashing of every 2nd scale segment
Average value	Adjustable from 1-30 measur.	Adjustable from 1-30 measur.
Input resistance	Clamp	Ri
	1	100 kΩ
	2	560 kΩ
	3	2.2 MΩ
	4	10 MΩ
	6	100 Ω
	7	10 Ω
	1	100 kΩ
	2	220 kΩ
	3	270 MΩ
	4	560 MΩ
	6	560 Ω
	7	68 Ω

DBA-EA30/F DBA -EA30/M



Digital bargraph for alternating current or voltage and temperature, programmable

Digital panel bargraph for monitoring and control with different interfaces and inputs

- AC current/voltage
- Temperature
- LED-displays red or green

Case 96 x 24 mm

Scale length 75 mm



DBA-EA30/XxxxH

Control elements behind the filter plate

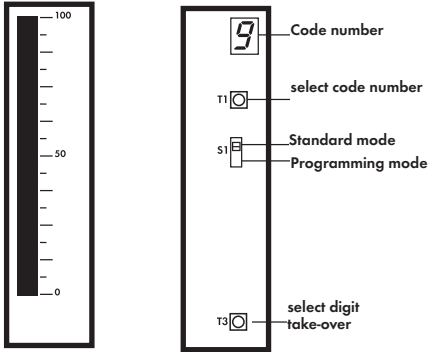

DBA-EA30/XxxxQ

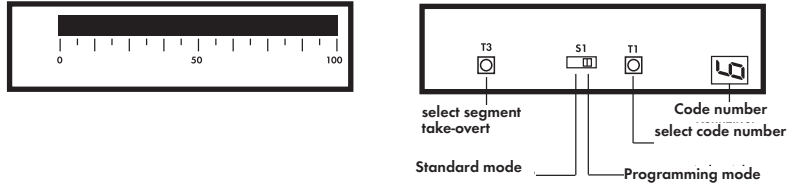

Technical Data

Type	DBA-EA30/F	DBA13-EA30/M
Input	AC current/voltage	Temperature
Panel cut-out (mm)	92(+0.8) x 22.2 (+0.6) mm	92(+0.8) x 22.2 (+0.3) mm
Front frame height (mm)	7.5	7.5
Mounting depth (mm)	115	115
Display/digit height (mm)	---	---
Scale length	75 mm/ 30 segments	75 mm/ 30 segments
Resolution measuring range	---	---
Resolution scale	1 segment	1 segment
	Final value of scale refers to the incoming indication final value	
LED-display colour	Red or green	Red or green
Option	Min.- Max.- Memory	Min.- Max.- Memory
Auxiliary supply		
DBA-EA.../F1 DBA-EA.../M1	18 - 35 V DC	18 - 35 V DC
DBA-EA.../M2 DBA-EA.../M2	115/230V AC	115/230V AC
Power consumption	Max. 2.5 VA	Max.2.5 VA
Measuring ranges voltage	2V/100V/200V/500V DC	---
Measuring ranges current	3A/6A AC	---
Measuring ranges PT100	---	-19.9 up to 99.9 °C -19.9 up to 800 °C -19.9 up to 99.9 °F -19.9 up to 999 °F
Display max.	Free programmable	---
Display zero	Free programmable	---
Conversion rate	Approx. 1 measurement/1 sec.	Approx. 1 measurement/1 sec.
Measuring principle	Dual-Slope-integration	Dual-Slope-integration
Measuring error	+/-0.2% of measuring value +/-1 digit/segment	+/-1K(PT100 200°C: +0.1K +/-1 digit/segment)
Overflow	Flashing of every 2nd scale segment	Flashing of every 2nd scale segment
Average value	Adjustable from 1-30 measur.	---

Pluggable screw terminal

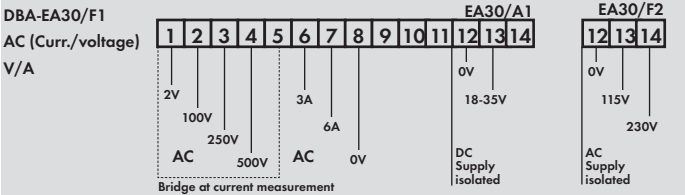

Pluggable screw terminal

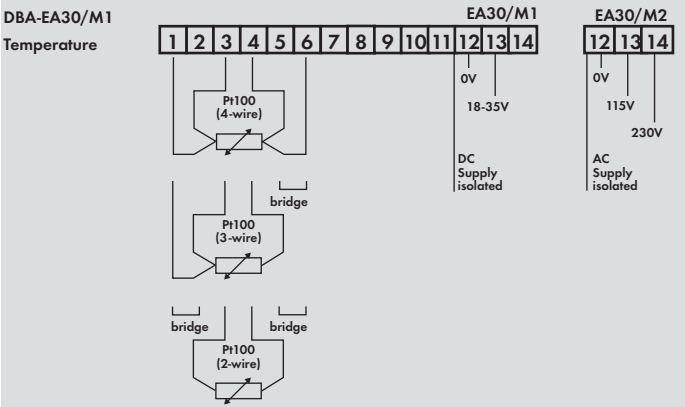

Display messages

EEP	EEProm under programming	
----	Overflow (Flashing of display segm. in th. middle)	
-	Line break indicator (Below measured value)	

Input resistance EA23/F	Clamp	Ri
	1	10 kΩ
	2	470 kΩ
	3	1 MΩ
	4	2.2 MΩ
	6	0.02 Ω
	7	0.01 Ω

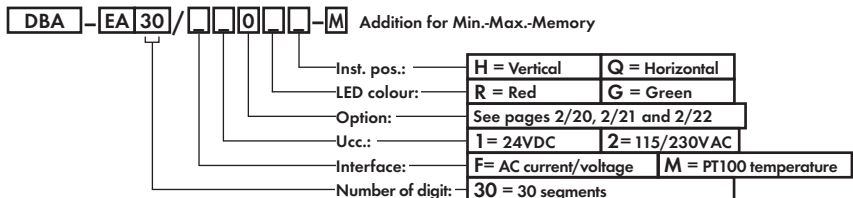

DBA-EA43/50/A DBA-EA43/50/F



Digital bargraph for norm signals, programmable

Digital bargraph panels for monitoring and control with different interfaces and inputs

- DC current/voltage (V/mA)
- AC current/voltage
- Bargraph and digital panel
- LED-displays red or green

Case 144 x 48 mm

Scale length 100 mm, 125 mm



DBA-EA43/xxxxQ

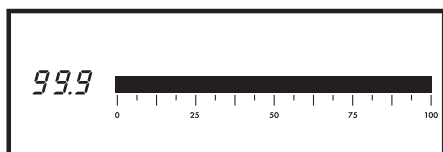

DBA-EA50/xxxxQ

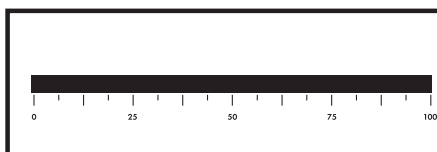

Control elements behind the filter plate

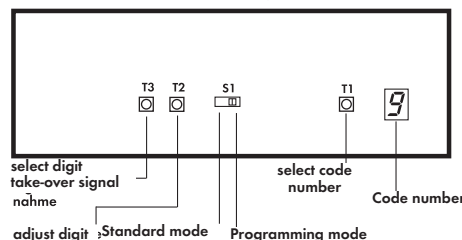
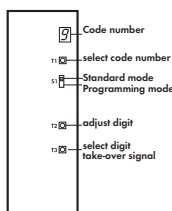
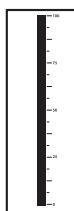
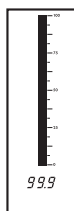

Illustration scaled down

DBA-EA43/xxxxH

DBA-EA50/xxxxH

Control elements behind the filter plate



Input resistance	Clamp	Ri
DBA-EA43/A	1	100 kΩ
DBA-EA50/A	2	560 kΩ
	3	2.2 MΩ
	4	12 MΩ
	6	100 Ω
	7	10 Ω

Input resistance	Clamp	Ri
DBA-EA43/F	1	10 kΩ
DBA-EA50/F	2	470 kΩ
	3	1 MΩ
	4	2.2 MΩ
	6	0.02 Ω
	7	0.01 Ω

Pluggable screw terminal DBA-EA43/A – DBA-EA50/A (DC current/voltage)

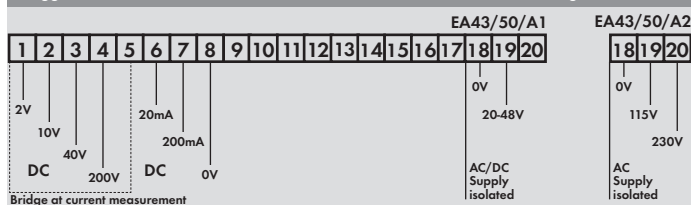

Pluggable screw terminal DBA-EA43/F – DBA-EA50/F (AC current/voltage)

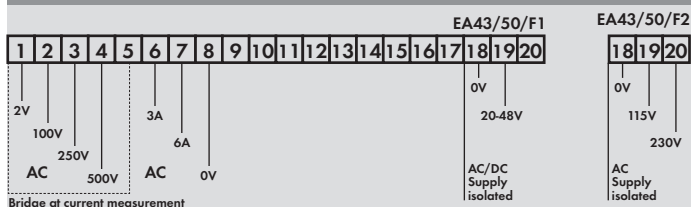

Ordering example

DBA-EA50/F...

- 50 - 125 mm luminous row panel
- F - AC current/voltage
- 2 - Ucc. 115/230 V AC
- 0 - Option
- R - Display colour red
- H - Vertical

= DBA-EA50/F20RH

Technical Data

Type	DBA-EA43/A – DBA-EA50/A	DBA-EA43/F – DBA-EA50/F
Input	DC current/voltage V/mA	AC current/voltage V/A
Panel cut-out (mm)	138(+1.0) x 45(+0.6) mm	138(+1.0) x 45(+0.6) mm
Front frame height (mm)	8.5	8.5
Mounting depth (mm)	115	115
Display/digit height (mm)	7 mm/ 3-digit (only EA43)	7 mm/ 3-digit (only EA43)
Scale length	EA43= 100 mm/40 segments EA50= 125 mm/50 segments	EA43= 100 mm/40 segments EA50= 125 mm/50 segments
Resolution measuring range	1 segment	1 segment
Resolution numbers	Final value of scale refers to the incoming indication final value -199 ...999 (only EA43)	-199 ...999 (only EA43)
LED-display colour	Red or green	Red or green
Option	Min.- Max.- Memory	Min.- Max.- Memory
Auxiliary supply	DBA-EA.../A1 DBA-EA.../F1 DBA-EA.../A2 DBA-EA.../F2	28 - 48 V AC/DC 115/230V AC Max. 2.5 VA
Measuring ranges voltage	2V/10V/40V/200V DC	18 - 35 V DC 115/230V AC Max.2.5 VA
Measuring ranges current	20mA/200mA DC	3A/6A AC
Display max.	Free programmable	Free programmable
Display zero	Free programmable	Free programmable
Conversion rate	Approx. 1 measurement/1sec.	Approx. 1 measurement/1sec.
Measuring principle	Dual-Slope-integration	Dual-Slope-integration
Measuring error	+/-0.01% of measuring value +/-1 digit/segment	+/-0.02% of measuring value +/-1 digit/segment
Overflow	Flashing of the middle segments and of every 2nd scale segment	Flashing of the middle segments and of every 2nd scale segment
Average value	Adjustable from 1-500 measur.	Adjustable from 1-30 measur.

Display messages

EEP	EEProm under programming	
----	Overflow (Flashing of display segm. in th. middle)	
⊥	Line break indicator (Below measured value)	

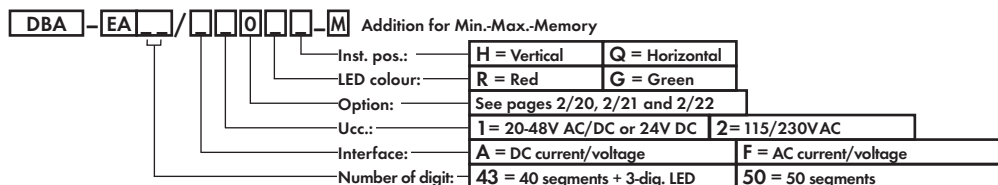

DBA-ESxx/P1xx



Digital bargraph for ProfiBus L2DP

Digital panel bargraph for monitoring and control with ProfiBus interface

- ProfiBus L2DP
- LED-displays red or green

Case 96 x 24 mm

Scale length 50 mm, 75 mm



DBA-ES23/P1xH

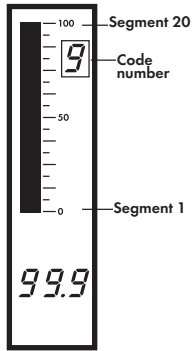

DBA-ES30/P1xH

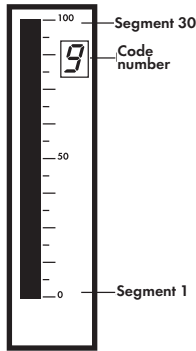

Case - topview front

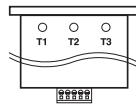

Back view

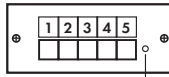

LED Data Exchange Mode

Technical Data

Type	DBA-ES30/P1xx	DBA-ES23/P1xx
Input	Profibus L2DP	Profibus L2DP
Panel cut-out (mm)	92(+0.8) x 22.2(+0.6) mm	92(+0.8) x 22.2(+0.6) mm
Front frame height (mm)	7.5	7.5
Mounting depth (mm)	91	91
Display/digit height (mm)	75 mm/30 segments	50 mm/20 segments
LED-display colour	Red or green	Red or green
Auxiliary supply	18 - 35 V DC	18 - 35 V DC
Power consumption	Max. 1.8 VA	Max. 1.8 VA
Temperature range	0°C ... +50°C	0°C ... +50°C
Baud rate (autom. recogn.)	≤12MBaud	≤12MBaud
Address (0 ...127)	Adjustable at the topside of case	Adjustable at the topside of case
Protocol	Profibus-DP	Profibus-DP
Hardware	SPC 3 Feldbus site galvanic insulated	SPC 3 Feldbus site galvanic insulated

Telegram construction BCD

Byte	Function ES30	Function ES30
1.	Segment 8 7 6 5 4 3 2 1	Segment 8 7 6 5 4 3 2 1
2.	Segment 16 15 14 13 12 11 10 9	Segment 16 15 14 13 12 11 10 9
3.	Segment 24 23 22 21 20 19 18 17	free Segment 20 19 18 17
4.	free free 28 27 26 25	Digit 10 ¹ Digit 10 ¹
5.	free free	free Digit 10 ²
6.	free free	free free
7.	free free	free free
8.	free free	free Comma Display

Telegram construction ASCII

Byte	Description	ASCII
1.	Segment 1 - 8	binary
2.	Segment 9 - 16	binary
3.	Segment 17 - 20	binary
4.	Digit 1 $\triangle 10^0$	3xH
5.	Digit 2 $\triangle 10^1$	3xH
6.	Digit 3 $\triangle 10^2$	3xH
7.		
8.	free	

DBA-ES23/P1xQ

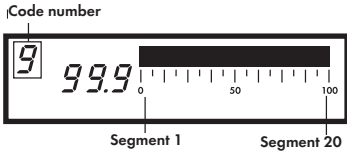

DBA-ES30/P1xQ

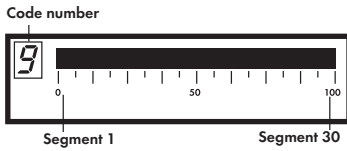

Sign rate

Hex	20	2D	2C	2E	30	31	32	33	34	35	36	37	38	39	3D	41	43	45	46	48	4C	50	55	5D	5F	62	63	64	68	6E	6F	72	75	78	7E
Digit	0	1	2	3	4	5	6	7	8	9	=	R	[E	F	K	L	P	U]	B	C	D	H	N	O	R	V	0	+	=

unknown sign

Pluggable screw terminal for Profibus

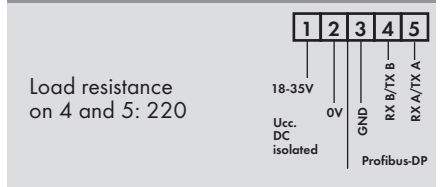

Load resistance on 4 and 5: 220

Ordering example

DBA-ES23/P1...

- 23- 20 segments + 3-dig.LED
- P - Profibus
- 1 - Ucc. 24 V DC
- R - Display colour red
- Q - Horizontal

= DBA-ES23/P1RQ



Inst. pos.:	H = Vertical	Q = Horizontal
LED colour:	R = Red	G = Green
Option:	See pages 2/20, 2/21 and 2/22	
Ucc.:	1 = 24V DC	
Interface:	P = Profibus L2DP	F = AC current/voltage
Number of digitl.:	23 = 20 segments + 3-dig. LED	30 = 30 segments

Options: for DBA-EA

Valid for:
DBA-EA23/A__
DBA-EA30/A__

Option: 1 Analogue output 0 - 10VDC

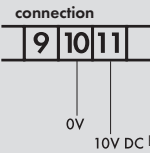

Max.+min. values of analogue output depend on min.+max measurements values under code number 1 + 3

Option: 2 Analogue output 0/4 - 20 mA DC

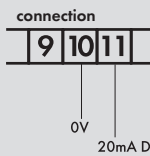

Max.+min. values of analogue output depend on min.+max measurements values under code number 1 + 3

Programming

Code	Display	Description
6	1__	Analogue output DC 0= 0 - 20mA 1= 4 - 20mA

Option: 7 1 Alarm contact open collector

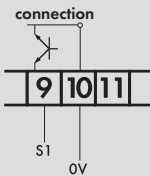

15 Watt max.
max. 30 V (0.5A)

Programming

..EA13, 23,43		..EA20, 30, 50	
Code	Display	Scale	Description
7	S1		Upper switching threshold
8	S1		Lower switching threshold
9	--1		0=inactive 1=active
	0		Operating current Max-contact
	1		Quiescent current Max-contact
	2		Operating current Min-contact
0	0__		Display normal if S1 ative
	1__		Display is flashing if S1 active

Option: 8 2 Alarm contacts open collector

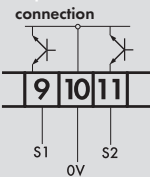

15 Watt max.
max. 30 V (0.5A)

Programming

..EA13, 23,43		..EA20, 30, 50	
Code	Display	Scale	Description
7	S1		Upper switching theshold
8	S1		Lower switching threshold
9	--1		0=inactive 1=active
	0		Operating current Max-contact
	1		Quiescent current Max-contact
	2		Operating current Min-contact
0	0__		Display normal if S1 ative
	1__		Display is flashing if S1 active

..EA13, 23,43		..EA20, 30, 50	
Code	Display	Scale	Description
A	S2		Upper switching theshold
b	S2		Lower switching threshold
C	--1		0=inactive 1=active
	0		Operating current Max-contact
	1		Quiescent current Max-contact
	2		Operating current Min-contact
0	0__		Display normal if S2 ative
	1__		Display is flashing if S2 active

Option: D Input for display blank

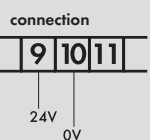

Input:	Active-high, 24V
L-signal:	Display shows present measurement value
H-signal:	Display blank

Option: H

Display-Hold

connection

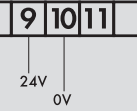

Input:	Active-high, 24V
L-signal:	Display shows present measurement value
H-signal:	Display blank

Option: R

2 Relais contacts

connection

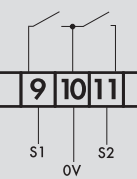

10 Watt max.
max. 200V (0,05A)
max. 0.5A (20V)

..EA13, 23,43		..EA20, 30, 50	
Code	Display	Scale	Description
7	S1		Upper switching threshold
8	S1		Lower switching threshold
9	--1		0=inactive 1=active
	0		Operating current Max-contact
	1		Quiescent current Max-contact
	2		Operating current Min-contact
	3		Quiescent current Min-contact
0	0_		Display normal if S1 active
1	1_		Display is flashing if S1 active

Programming

..EA13, 23,43		..EA20, 30, 50	
Code	Display	Scale	Description
A	S2		Upper switching threshold
b	S2		Lower switching threshold
C	--1		0=inactive 1=active
	0		Operating current Max-contact
	1		Quiescent current Max-contact
	2		Operating current Min-contact
	3		Quiescent current Min-contact
0	0_		Display normal if S2 active
1	1_		Display is flashing if S2 active

Option: S

Serial output RS232

connection

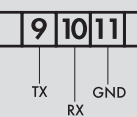

Code	Display	Description	
7	--0	0= 150 Baud 4= 150 Baud	
	---	1= 300 Baud 5= 4800 Baud	
	---	2= 600 Baud 6= 9600 Baud	
	---	3= 1200 Baud 7= 19200 Baud	
	0	0= without parity 8 data bits	
	---	1= party even 7 data bits	
	---	2= party odd 7 data bits	
	---	3= party even 8 data bits	
	---	4= party odd 8 data bits	
	8	---	address of display unit
		_00	no address
		--X	address 10 ⁰
-X-		address 10 ¹	

Programming

Code	Display	Description
9	--X	Direction of writing 0= left 1= right
	0	0= Serial output off
	---	1= digit sign/ value
	---	2= STX/ sign/ value/ ETX
	---	3= STX/ adr./ sign/ value/ ETX
	---	4= SOH/ adr./ STX/ sign/ value/ ETX
	---	Transfer instruction
	0_	off
	1_	Transfer after received address
	2_	Transfer after STX/ adr./ ETX received

Option: -M

Min.- Max.- Memory

..EA13, 23, 43 The buttons T1- T3 are inserted through a filter plate. By activating the T1 longer than 5 seconds a reference measurement is effected. If T1 is activated for a duration of fewer than 5 seconds the up to now saved min.-max.-values are deleted. The value of reference measurement is maintained. Afterwards by T2 (max.-value) and T3 (min.-value) the respective extreme value can be recalled with regard to the reference measurement.

..EA20, 30, 50 The buttons T1- T3 are inserted through a filter plate. By activating the T2 (max.-value) and T3 (min.-value) the respective extreme value is indicated. If T1 is activated the up to now saved min.-max.-values are deleted.

Options: for DBA-EA43 + EA50

Valid for:
DBA-EA43/A__
DBA-EA50/A__

Option: 8 **2 Alarm contact open collector**

connection

15 Watt max.
max. 30V (0.5A)

Code	Display	Scale	Description	Button
7	S1		Upper switching theshold	T3
8	S1		Lower switching threshold	T3
9	--0		0=inactive	T2
	--1		activ (left lower light band)	
	--2		activ (right upper light band)	
	-0-		Operating current Max-contact	T3
	-1-		Quiescent current Max-contact	
	-2-		Operating current Min-contact	
	-3-		Quiescent current Min-contact	
0--		Display normal if S1 ative		
1--		Display is flashing if S1 active		

Programming

..EA43 ..EA50

Code	Display	Scale	Description	Button
A	S2		Upper switching theshold	T3
b	S2		Lower switching threshold	T3
C	--0		0=inactive	T2
	--1		activ (left lower light band)	
	--2		activ (right upper light band)	
	-0-		Operating current Max-contact	T3
	-1-		Quiescent current Max-contact	
	-2-		Operating current Min-contact	
	-3-		Quiescent current Min-contact	
0--		Display normal if S2 ative		
1--		Display is flashing if S2 active		

Option: R **2 Relais contacts**

connection

200 Watt max.
max. 250V (0.8A)
max. 4A (50V)

Code	Display	Scale	Description	Button
7	S1		Upper switching theshold	T3
8	S1		Lower switching threshold	T3
9	--0		0=inactive	T2
	--1		activ (left lower light band)	
	--2		activ (right upper light band)	
	-0-		Operating current Max-contact	T3
	-1-		Quiescent current Max-contact	
	-2-		Operating current Min-contact	
	-3-		Quiescent current Min-contact	
0--		Display normal if S1 ative		
1--		Display is flashing if S1 active		

Programming

..EA43 ..EA50

Code	Display	Scale	Description	Button
A	S2		Upper switching theshold	T3
b	S2		Lower switching threshold	T3
C	--0		0=inactive	T2
	--1		activ (left lower light band)	
	--2		activ (right upper light band)	
	-0-		Operating current Max-contact	T3
	-1-		Quiescent current Max-contact	
	-2-		Operating current Min-contact	
	-3-		Quiescent current Min-contact	
0--		Display normal if S2 ative		
1--		Display is flashing if S2 active		

Option: D **Display-Hold**

connection

Input:	Active-high, 24V
L-signal:	Display shows present measurement value
H-signal:	Display blank

DA20-NAxx/Xxxx



Digital panel instruments for standard signals, programmable

Digital large panel display for monitoring and control with different interfaces and inputs



- DC current/voltage (V/mA) **DA20 = Digit height 20.0 mm**
- AC current/voltage
- LED-displays red or green
- Up to 5-digit displays

DA20-NAxx/Axxx

Case 144 x 48mm



DA20-NAxx/Axxx

Case 144 x 72mm



DA20-NAxx/Fxxx

Case 144 x 72mm



DA20-NAxx/Fxxx

Case 144 x 48mm



Technical Data

Type	DA20-NAxx/Axxx	DA20-NAxx/Fxxx
Input	DC current/voltage V/mA	DC current/voltage V/A
Panel cut-out (mm)		
DA20-NAxx/Xxxx	138(+1.0) x 45.0(+0.6) mm	138(+1.0) x 45.0(+0.6) mm
DA20-NAxx/Xxxx-4	138(+1.0) x 68.0(+0.7) mm	138(+1.0) x 68.0(+0.7) mm
Front frame height (mm)	8.5	8.5
Mounting depth (mm)	115	115
Display/digit height (mm)	20.0	20.0
LED-display colour	Red or green	Red or green
Auxiliary supply		
DA20-NAxx/X1xx	18 - 35 V DC	18 - 35 V DC
DA20-NAxx/X2xx	115/230V AC	115/230V AC
Power consumption	Max. 5 VA	Max. 5 VA
Measuring ranges voltage	2V/10V/40V/200V DC	2V/100V/250V/500V AC
Measuring ranges current	20mA/200mA DC	3A/6A AC
Display max.	Free programmable	Free programmable
Display zero	Free programmable	Free programmable
Conversion rate	Approx. 1 measurement/1 sec.	Approx. 1 measurement/1 sec.
Measuring principle	Dual-Slope-integration	Dual-Slope-integration, True RMS
Measuring error	+/-0.01% of measuring value +/-1 digit/segment	+/-0.2% of measuring value +/-1 digit/segment
Average value	Adjustable from 1-500 measur.	Adjustable from 1-500 measur.

Display messages

EEP	EEProm under programming
----	Overflow (Flashing of display segments in middle)
⊥	Line break indicator (Undercut of measuring value)

Number of digits

DA20-NA30/Axxx	888
DA20-NA31/Axxx	± 1888
DA20-NA40/Axxx	8888
DA20-NA41/Axxx	± 18888
DA20-NA50/Axxx	88888
DA20-NA30/Fxxx	888
DA20-NA40/Fxxx	8888

Resolution

..NA30..	-199	... 999
..NA31..	-1999	...+1999
..NA40	-1999	... 9999
..NA41..	-19999	...+19999
..NA50..	-19999	... 30000

Control elements behind the filter plate

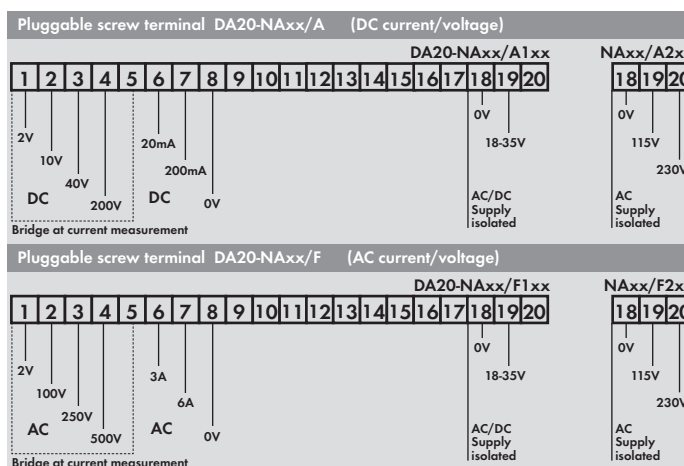
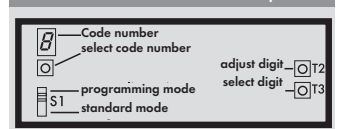

Input resistance	Clamp	Ri
DA20-NAxx/Axx	1	100 kΩ
	2	560 kΩ
	3	2.2 MΩ
	4	12 MΩ
	6	100 Ω
	7	10 Ω
	DA20-NAxx/Fxx	1
2		470 kΩ
3		1 MΩ
4		2.2 MΩ
6		0.02 Ω
7		0.01 Ω

Ordering example

DA20-NA...

- 31 - Figures 3- 1/2-digit
- A - DC current/voltage
- 2 - Ucc. 115/230V AC
- G - Display colour green
- 4 - Case 144 x 72 mm

= DA20-NA31/A20G-4

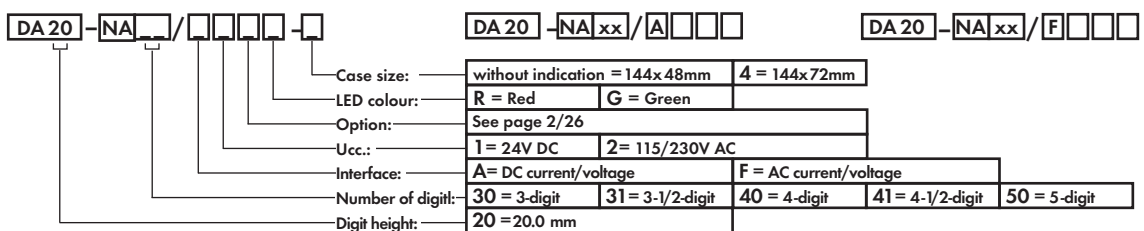

DA20-NAxx/F (AC current/voltage) only available 3 or 4-digits

DA25-NAxx/Xxxx



Digital panels for norm signals, programmable

Digital large panel displays for monitoring and control with different interfaces and inputs



- DC current/voltage (V/mA)
 - AC current/voltage
 - LED-displays red or green
 - Up to 4-digit displays
- DA25 = Digit height 25.0 mm**

DA25-NAxx/Axxx

Case 144 x 48mm



DA25-NAxx/Axxx

Case 144 x 72mm



DA25-NAxx/Fxxx

Case 144 x 48mm



DA25-NAxx/Fxxx

Case 144 x 72mm



Technical Data

Type	DA25-NAxx/Axxx	DA25-NAxx/Fxxx
Input	DC current/voltage V/mA	AC current/voltage V/A
Panel cut-out (mm)	DA25-NAxx/Xxxx 138(+1.0) x 45.0(+0.6) mm DA25-NAxx/Xxxx-4 138(+1.0) x 68.0(+0.7) mm	138(+1.0) x 45.0(+0.6) mm 138(+1.0) x 68.0(+0.7) mm
Front frame height (mm)	8.5	8.5
Mounting depth (mm)	115	115
Display/digit height (mm)	25.0	25.0
LED-display colour	Red or green	Red or green
Auxiliary supply	DA25-NAxx/X1xx 18 - 35 V DC DA25-NAxx/X2xx 115/230V AC	18 - 35 V DC 115/230V AC
Power consumption	Max. 5 VA	Max. 5 VA
Measuring ranges voltage	2V/10V/40V/200V DC	2V/100V/250V/500V AC
Measuring ranges current	20mA/200mA DC	3A/6A AC
Display max.	Free programmable	Free programmable
Display zero	Free programmable	Free programmable
Conversion rate	Approx. 1 measurement/1sec.	Approx. 1 measurement/1sec.
Measuring principle	Dual-Slope-integration	Dual-Slope-integration
Measuring error	+/-0.01% of measuring value +/-1 digit/segment	+/-0.2% of measuring value +/-1 digit/segment
Average value	Adjustable from 1-500 measur.	Adjustable from 1-500 measur.

Display messages

EEP	EEProm under programming
----	Overflow (Flashing of display segments in middle)
⊥	Line break indicator (Undercut of measuring value)

Number of digit

DA25-NA30/Axxx/Fxxx	888
DA25-NA31/Axxx	± 1888
DA25-NA40/Axxx/Fxxx	8888

Resolution

..NA30/Axxx	-199	... 999
..NA31/Axxx	-1999	...+ 9999
..NA40/Axxx	-1999	... 99999
..NA30/Fxxx	0	... 999
..NA40/Fxxx	0	... 9999

Control elements behind the filter plate

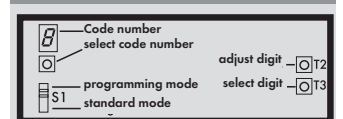

Pluggable screw terminal DA25-NAxx/A (DC current/voltage)

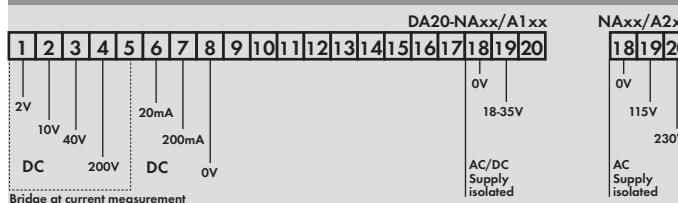

Pluggable screw terminal DA25-NAxx/F (AC current/voltage)

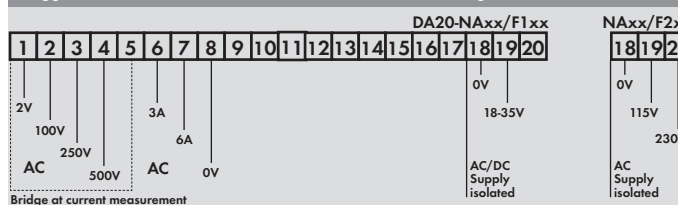

Input resistance	Clamp	Ri
DA25-NAxx/Axx	1	100 kΩ
	2	560 kΩ
	3	2.2 MΩ
	4	12 MΩ
	6	100 Ω
	7	10 Ω
	DA25-NAxx/Fxx	1
2		470 kΩ
3		1 MΩ
4		2.2 MΩ
6		0.02 Ω
7		0.01 Ω

Ordering example

DA25-NA...

- 40 - Figures 4-digit
- F - DC current/voltage
- 1 - Ucc. 24 V DC
- G - Display colour green
- 4 - Case 144 x 72 mm

= DA20-NA40/F10G-4

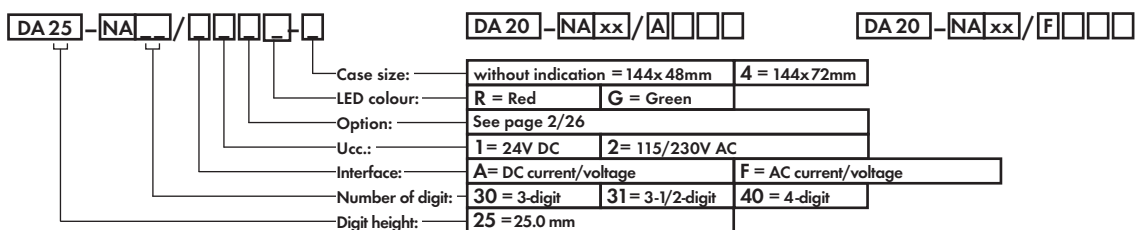

DA25-NAxx/F (AC current/voltage) only available 3 or 4-digits

Options: for DA20-NA
DA25-NA
DA40-NA

Valid for:
DA20-NAxx/Axx
DA20-NAxx/Fxx
DA25-NAxx/Axx
DA25-NAxx/Fxx
DA40-NAxx/Axx
DA40-NAxx/Fxx

Option: R 2 Relais contacts

connection



200 Watt max.
max. 250V (0.8A)
max. 4A (50V)

Code	Display	Description
7	S1	Upper switching threshold
8	S1	Lower switching threshold
9	__1	0=inactive 1=active
	__0__	Operating current Max-contact
	__1__	Quiescent current Max-contact
	__2__	Operating current Min-contact
0	__3__	Quiescent current Min-contact
	0__	Display normal if S1 active
1	1__	Display is flashing if S1 active

Programming

Code	Display	Description
A	S2	Upper switching threshold
b	S2	Lower switching threshold
C	__1	0=inactive 1=active
	__0__	Operating current Max-contact
	__1__	Quiescent current Max-contact
	__2__	Operating current Min-contact
0	__3__	Quiescent current Min-contact
	0__	Display normal if S2 active
1	1__	Display is flashing if S2 active

Option: V Serial output RS485

connection

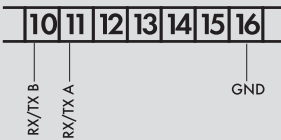

Code	Display	Description
7	__0	0= 150 Baud 4= 150 Baud
	__1	1= 300 Baud 5= 4800 Baud
	__2	2= 600 Baud 6= 9600 Baud
	__3	3= 1200 Baud 7= 19200 Baud
	__0__	0= without parity 8 data bits
	__1	1= parity even 7 data bits
	__2	2= parity odd 7 data bits
	__3	3= parity even 8 data bits
	__4	4= parity odd 8 data bits
	8	__
__00		no address
__X		address 10 ⁰
__X		address 10 ¹

Programming

Code	Display	Description
9	__X	Direction of writing 0= left 1= right
	__0__	0= Serial output off
	__1	1= digit sign/ value
	__2	2= STX/ sign/ value/ ETX
	__3	3= STX/ adr./ sign/ value/ ETX
	__4	4= SOH/ adr./ STX/ sign/ value/ ETX
	__	Transfer instruction
	0__	off
	1__	Transfer after received address
	2__	Transfer after STX/ adr./ ETX received

Option: D Input for display blank

connection

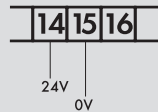

Input:	Active-high, 24V
L-signal:	Display shows measurement value
H-signal:	Display blank

Large panels with digit height up to 300 mm on request.

M1-7S...

Programmable Digital Panel Instrument M1-Current Loop, 48 x 24 mm 88



- Red display of -1999 up to 9999
- Minimal installation depth: 27 mm without plug-in terminal
- Adjustment via factory default or directly on the sensor signal
- Min-/max-value recording
- Display flashing at threshold exceedance / undercut
- Tara-function
- Protection class IP65
- 10 adjustable setpoints
- Programming interlock via access code
- Plug-in terminal

M1-7S
Case 48 x 24 mm



EMV EN 61326

CE-sign Conformity to 2004/108/EG

Safety standard EN 61010

General Technical Data, Type M1-7S

Case	B48 x H24 x D27 mm
Panel cut-out	45.0 ^{+0.6} x 22.2 ^{+0.3} mm
Fixing	Screw elements for insulation thickness up to 3 mm
Case material	PC Polycarbonate, black
Protection class	Front IP65 standard Rear side IP00
Weight	Approx. 50 g
Connection	Plug terminal; line cross section up to 2.5mm ²
Digit height/Colour	10mm/red
Display range	-1999 to 9999
Setpoints	Optical display flashing
Display/measuring time	0.1 to 0.0 seconds
Input	Min. 3.5 ...max. 21 mA (4-20mA)
Measuring error	0.3%v. of measuring range, ±1 digit
Fail of voltage	Approx. 5.1 V
Data life	≥ 100 years; Flash-memory (independent of supply)
Working/Storing temperature	0 to 60°C (-20 to +80°C)
Climatic density	Relative humidity 0-80% on years average without dew

Current loop device

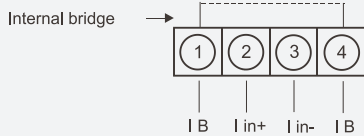

Supply

24 V DC

Order number (without options)

M1-7VR4A.0001.570BD

Connection pictures

Current loop device in combination with a transmitter in current loop technique:

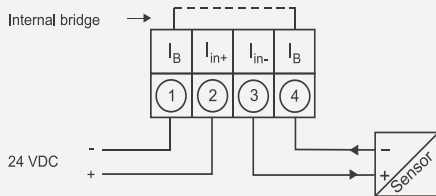

Current loop device with 3-/4-wire sensor:

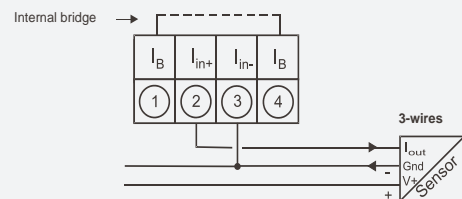

Current loop device in combination with another measuringout with low burden:

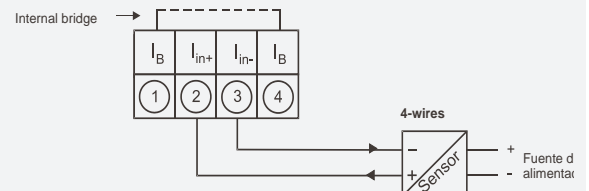
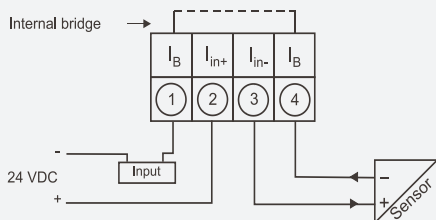

Dimensions

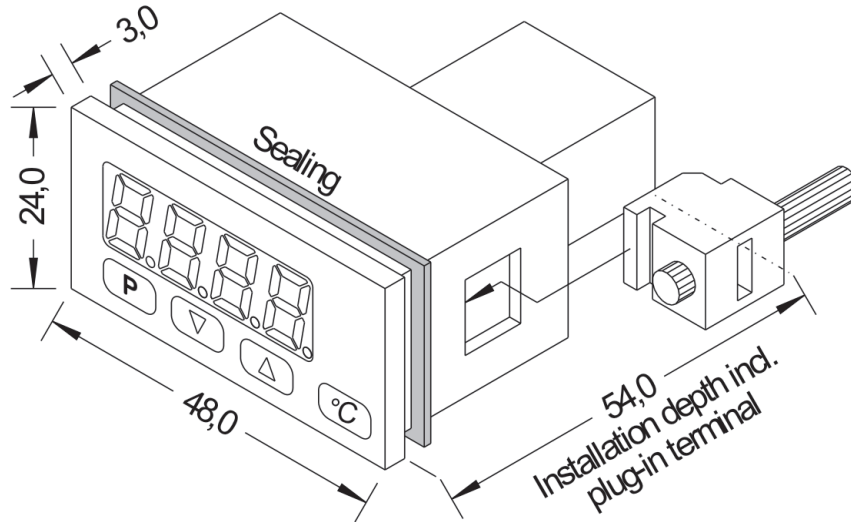

Ordering code M1-Current Loop 48 x 24 mm

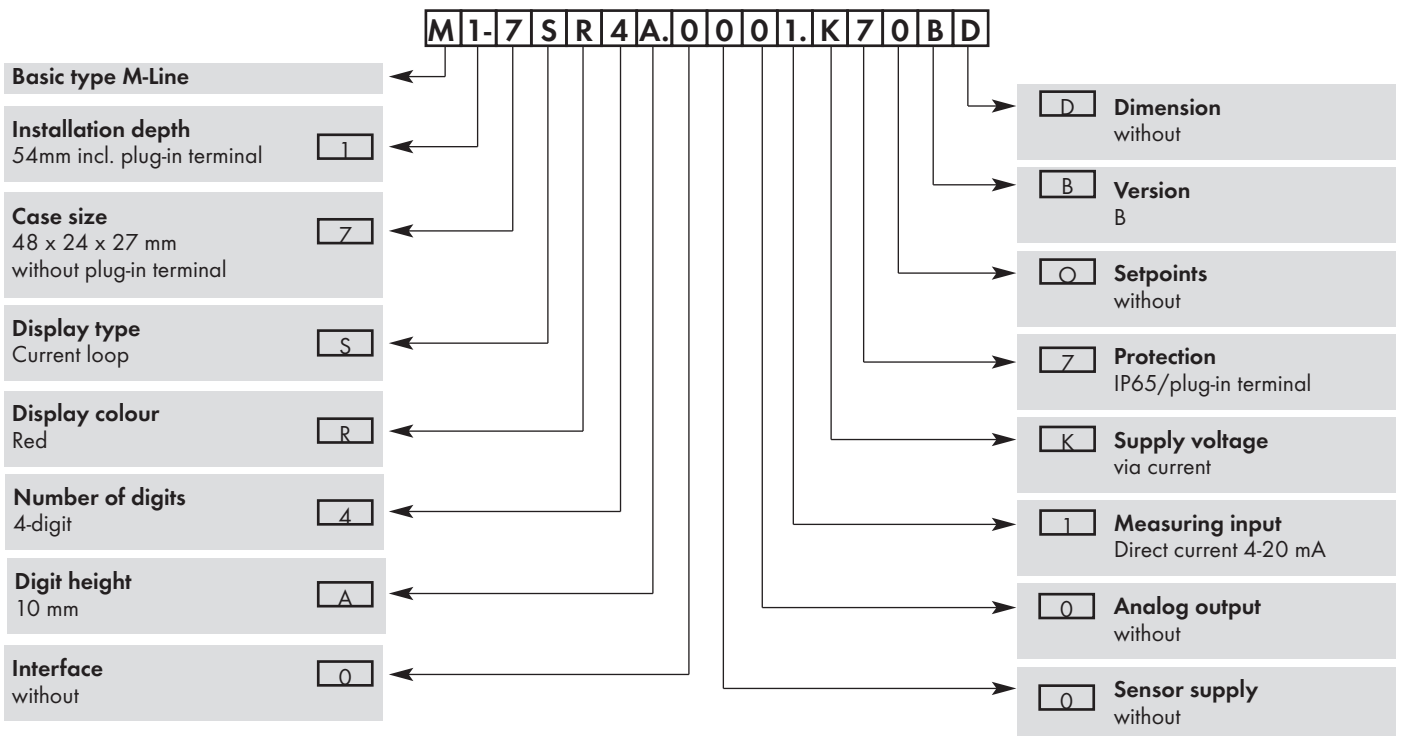

M1-7V.../ M1-7T...



Programmable Digital Panel Instrument 48 x 24 mm



- Red display of -1999 up to 9999 (optional green, orange or blue displays)
- Minimal installation depth: 27 mm without plug-in terminal
- Adjustment via factory default or directly on the sensor signal
- Min-/max-value recording
- 10 adjustable setpoints
- Display flashing at threshold exceedance / undershooting
- Tara-function
- Programming interlock via access code
- Protection class IP65
- Plug-in terminal

M1-7V.../ M1-7T
Case 48 x 24 mm



EMV	EN 61326
CE-Sign	Conformity to 2004/108/EG
Safety	EN 61010

Direct current, direct voltage

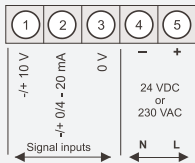

Supply	Order number (without options)
24V DC (galvanically insulated)	M1-7VR4A.0001.770BD

Direct voltage (Shunt)

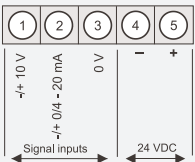

Supply	Order number (without options)
24V DC (galvanically insulated)	M1-7VR4A.0002.770BD

Potentiometer 0-100 % (>1 kΩ ... <1000 kΩ)

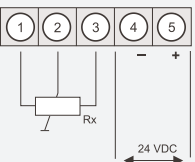

Supply	Order number (without options)
24V DC (galvanically insulated)	M1-7VR4A.0005.770BD

Resistance (1kΩ, 10kΩ, 100kΩ or 1000kΩ)

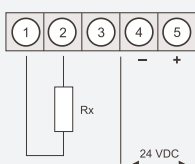

Supply	Order number (without options)
24V DC (Measuring range 1 kΩ)	M1-7VR4A.0806.770BD
24V DC (Measuring range 10 kΩ)	M1-7VR4A.0506.770BD
24V DC (Measuring range 100 kΩ)	M1-7VR4A.0606.770BD
24V DC (Measuring range 1 MΩ)	M1-7VR4A.0706.770BD

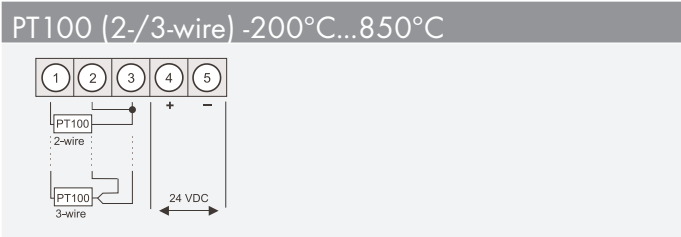

Supply	Order number (without options)
24V DC	M1-7TR4A.030C.770BD

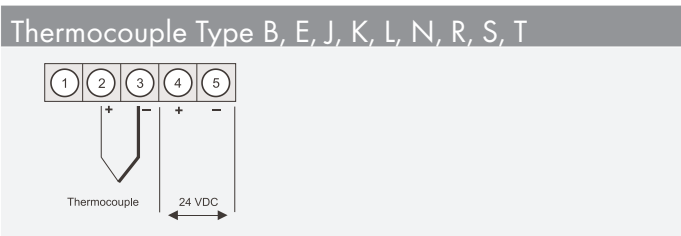

Supply	Order number (without options)
24V DC	M1-7TR4A.040X.770BD

OPTIONS	Availability
Blue LED	●
Orange LED	●
Green LED	●

Connection examples

M1 in combination with a 2-wire-sensor 4-20 mA

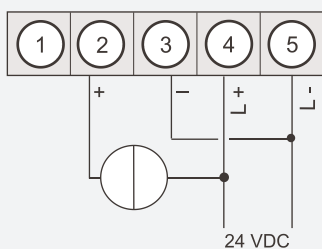

M1 in combination with a 3-wire-sensor 0/4-20 mA

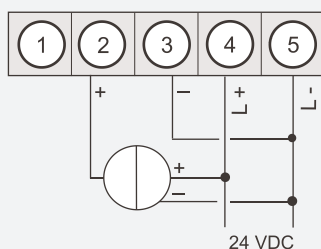

M1 in combination with a 3-wire-sensor 0-10 V

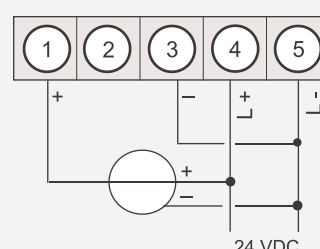

DIGITAL PANEL INSTRUMENTS

Ordering code M1-Standard 48 x 24 mm

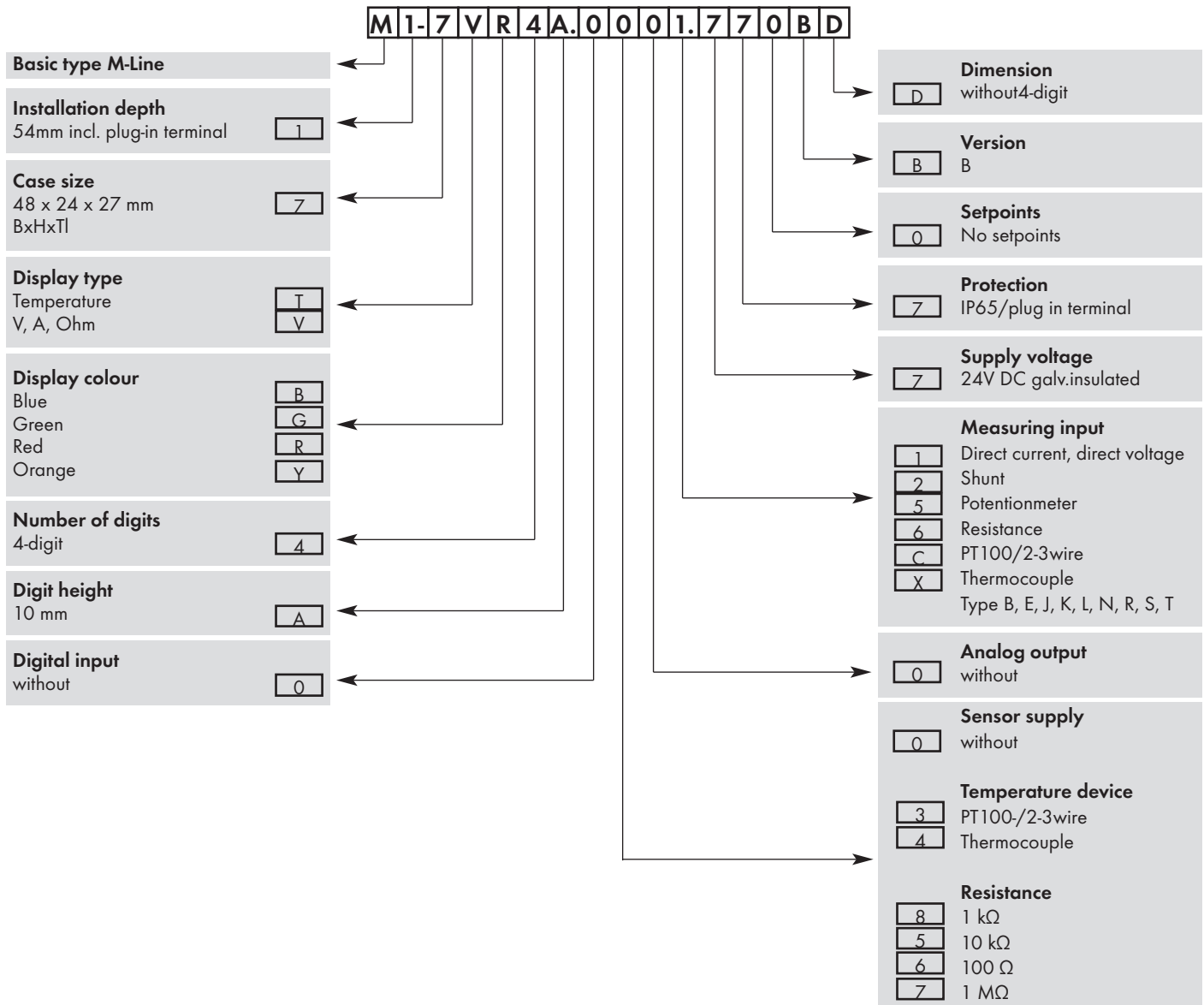

Dimensions

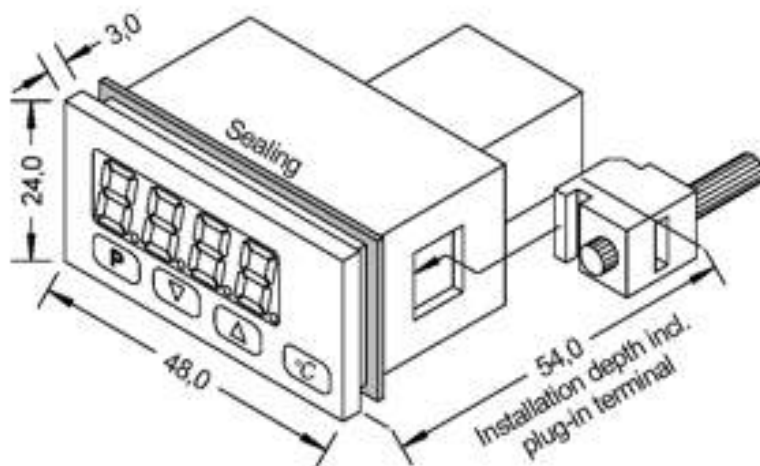

Technical Data

Dimensions

Case	B48 x H24 x D27 mm, (including plug-in terminal D=54 mm)
Panel cut-out	45,0 +0,8 x 22,2 +0,6 mm
Fixing	Screw elements for insulation thickness up to 3 mm
Case material	PC Polycarbonate, black
Sealing material	EPDM, 65 Shore, black
Protection class	At the front IP65 Standard
	Backside IP00
Weight	Approx. 20 g
Connection	Plug-in terminal; line cross-section up to 2.5 mm ²

Display

Display	4-digit
Digit height	10 mm
Segment colour	Red (standard), optional available in green, blue and orange
Display range	-1999 to 9999
Setpoints	Optical display flashing
Overflow/Underflow	Horizontal bars at the top/ horizontal bars at the bottom
Display time/Measuring time	0.1 to 10.0 seconds

Measuring input

M1-7VR4B.0001... Direct current/ Direct voltage	Span	-12 ...12 V	/22 ...24 mA
	Measuring range	0-10 VDC	/0/4-20 mA
	Input resistance	Ri at ~200 kΩ	Ri at ~100 Ω
	Measuring error	0.1% of measuring range, +/- 1 Digit	/0.1% of measuring range, +/- 1 Digit
	Temperature drift	100ppm/K	
	Measuring time/principle	0.1 ...10.0 seconds/ U/F-conversion	
	Resolution	Approx. 18Bit at 1s measuring time	

Measuring input

M1-7VR4B.0002... Shunt	Span	-5 ...80 mV	/-10 ...180 mV
	Measuring range	0 ...60 mV	/0 ...150 mV
	Input resistance	Ri at ~12 kΩ	Ri at ~30 kΩ
	Measuring error	0.1% of measuring range, +/- 1 Digit	/0.1% of measuring range, +/- 1 Digit
	Temperature drift	100ppm/K	
	Measuring time/principle	0.1 ...10.0 seconds/ U/F-conversion	
	Resolution	Approx. 18Bit at 1s measuring time	

Measuring input

M1-7VR4B.0005... Potentionmeter	Span	>1 kΩ ...1000 kΩ
	Measuring range	0-100%
	Measuring error	0.1% of measuring range, +/- 1 Digit
	Temperature drift	100ppm/K
	Measuring time/principle	0.1 ...10.0 seconds/ U/F-conversion
	Resolution	Approx. 18Bit at 1s measuring time

Measuring input

M1-7VR4B.0x06... Resistance	Span	0...1,1 kΩ, 0...11 kΩ, 0...110 kΩ, 0...1100 kΩ
	Measuring range	0...1kΩ, 0...10 kΩ, 0...100 kΩ, 0...1000 kΩ
	Measuring error	0.5% of measuring range, +/- 1 Digit
	Temperature drift	100ppm/K
	Measuring time/principle	0.1 ...10.0 seconds/ U/F-conversion
	Resolution	Approx. 18Bit at 1s measuring time

Measuring input

M1-7TR4B.030C... PT100	Measuring range	-200 ...850 °C/ -328 ...1562 °F
	Measuring error	0.1% of measuring range, +/- 1 Digit
	Temperature drift	100ppm/K
	Measuring time/principle	0.1 ...10.0 seconds/ U/F-conversion
	Resolution	Approx.0.1 °C or 0.1 °F

Measuring input

M1-7TR4B.040X... Thermocouple	Measuring range	Type L -200...900 °C	Type B 80...1820 °C	Type E -270... 1000 °C
		Type J -210...1200 °C	Type S -50...1768 °C	Type T -270...400 °C
		Type K -270...1372 °C	Type N -270...1300 °C	Type R -50...1768 °C
	Measuring error	2K, +/- 1 Digit		
	Temperature drift	100ppm/K		
	Measuring time/principle	0.1 ...10.0 seconds/ U/F-conversion		
	Resolution	0.1 °C		
	Characteristic curve error	> +/- 1 kΩ		
	Reference junction	Semiconductor sensor		

Power pack

Supply	24 VDC +/- 10%, galvanic insulated (max.1 VA)
--------	---

Memory

EEPROM Data life	≥ 100 years
---------------------	-------------

Ambient conditions

Working temperature	0 to +60 °C
Storing temperature	-20 to +80
Climatic density	Relative humidity 0-85% on years average without dew

M1-6S...

Programmable Digital Panel Instrument M1-Current Loop, 72 x 36 mm



- Red display of -1999 up to 9999
- Minimal installation depth: 25 mm without plug-in terminal
- Min-/max-value recording
- Adjustment via factory default or directly on the sensor signal
- Display flashing at threshold exceedance/ undershooting
- Tara-/ offset value calibration
- 10 adjustable setpoints
- Programming interlock via access code
- Protection class IP65 at the front
- Plug-in terminal

M1-S
Case 72 x 36mm



EMV EN 61326

CE-sign Conformity to 2004/108/EG

Safety standard EN 61010

General Technical Data, Type M1-S

Case	B72 x H36 x D26 mm (incl. plug-terminal D=38mm)
Panel cut-out	68.0 ^{+0.7} x 33.0 ^{+0.6} mm
Fixing	Screw elements for insulation thickness up to 3 mm
Case material	PC, Polycarbonate, black
Protection class	Front IP65 standard Rear side IP00
Weight	Approx. 100 g
Connection	Plug terminal; line cross section up to 2.5mm ²
Digit height/Segment Colour	14mm/ red
Display range	-1999 to 9999
Setpoints	Optical display flashing
Display/measuring time	0.1 to 0.0 seconds
Input	Min. 3.5 ...max. 21mA (4-20mA)
Measuring error	0.3%v. of measuring range, ±1 digit
Fail of voltage	Approx. 5.1 V without switching outputs Approx. 8.0 V with switching outputs
Data life	≥ 100 years; Flash-memory (independent of supply)
Working/Storing temperature	0 to 60°C/ -20 to +80°C
Climatic density	Relative humidity 0-80% on years average without dew

Current loop device

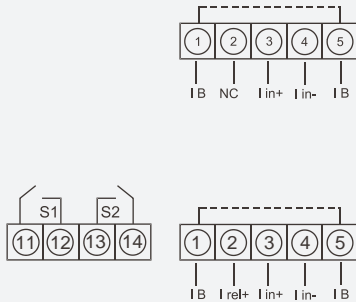

Order number (without options)

M1-6SR4B.0001.K70AD

M1-6SR4B.0001.K72AD

Connection pictures

Current loop device in combination with a transmitter in current loop technique:

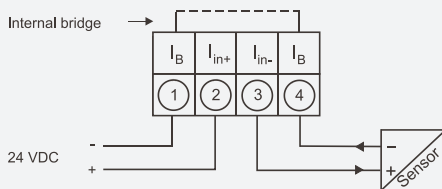

Current loop device in combination with a 3-/4-wire sensor:

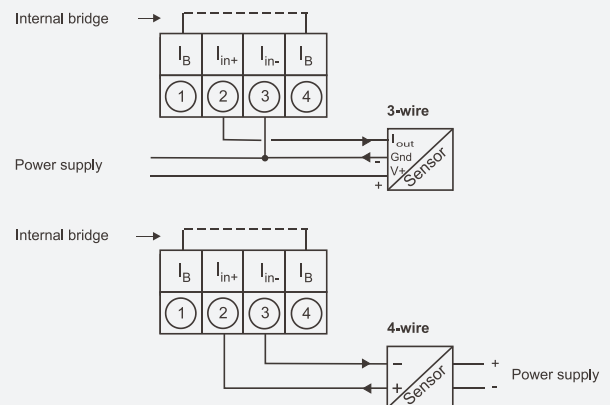

Current loop device in combination with another measuringout with low burden:

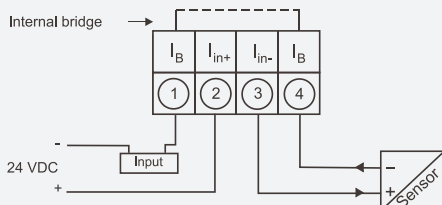



Dimensions

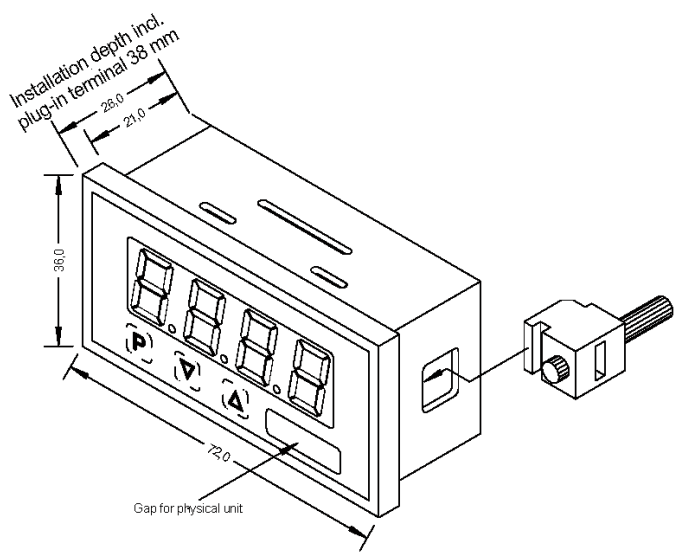

Ordering code M1-Current Loop 72 x 36 mm

M1-6SR4B.0001.K70AD

Basic type M-Line	M	Dimension physical unit (free choice)	D
Installation depth 37mm incl. plug-in terminal	1	Version A	A
Case size 72 x 36 x 2 mm	6	Setpoints without PhotoMOS-outputs	0 2
Display type Current loop	S	Protection without keypad, operation on the back IP65/plug terminal	1 7
Display colour Red	R	Supply voltage via current	K
Number of digits 4-digit	4	Measuring input Direct current 4-20 mA	1
Digit height 14 mm	B	Analog output without	0
Interface without	0	Sensor supply without	0

M1-6V.../ M1-6T...



Programmable Digital Panel Instrument 72 X 36 mm



- Red display of -1999 up to 9999 (optional green, orange or blue displays)
- Minimal installation depth: 97 mm without plug-in terminal
- Min-/max-value recording
- 10 adjustable setpoints
- Display flashing at threshold exceedance / undershooting
- Tara-function
- Adjustment via factory default or directly on the sensor signal
- Programming interlock via access code
- Protection class IP65
- Plug-in terminal

M1-6V.../ M1-6T
Case 72 x 36 mm



EMV EN 61326
CE-Sign Conformity to 2004/108/EG
Safety EN 61010

Direct current, direct voltage

Supply	Order number (without options)
230V AC	M1-6VR4B.0001.570AD
24V DC	M1-6VR4B.0001.770AD

Direct voltage (Shunt)

Supply	Order number (without options)
230V AC	M1-6VR4B.0002.570AD
24V DC	M1-6VR4B.0002.770AD

Potentiometer 0-100 % (>1 kΩ... <1000 kΩ)

Supply	Order number (without options)
230V AC	M1-6VR4B.0005.570AD
24V DC	M1-6VR4B.0005.770AD

Resistance (1kΩ, 10kΩ, 100kΩ or 1000kΩ)

Supply	Order number (without options)
230V AC	(Measuring range 1 kΩ) M1-6VR4B.0806.570AD
24 V DC	(Measuring range 1 kΩ) M1-6VR4B.0806.770AD
230V AC	(Measuring range 10 kΩ) M1-6VR4B.0506.570AD
24 V DC	(Measuring range 10 kΩ) M1-6VR4B.0506.770AD
230V AC	(Measuring range 100 kΩ) M1-6VR4B.0606.570AD
24 V AC	(Measuring range 100 kΩ) M1-6VR4B.0606.770AD
230V AC	(Measuring range 1000 kΩ) M1-6VR4B.0706.570AD
24 V DC	(Measuring range 1000 MΩ) M1-6VR4B.0706.770AD

PT100 (2-/3-wire) -200°C...850°C

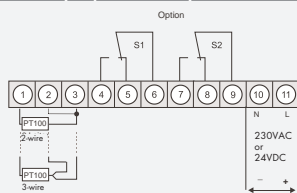

Supply	Order number (without options)
230V AC	M1-6TR4B.030C.570AD
24V DC	M1-6TR4B.030C.770AD

Thermocouple Type B, E, J, K, L, N, R, S, T

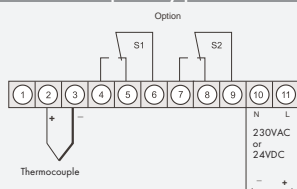

Supply	Order number (without options)
230V AC	M1-6TR4B.040X1.570AD
24V DC	M1-6TR4B.040X1.770AD

Connection examples

M1 in combination with a 2-wire sensor 4-20 mA

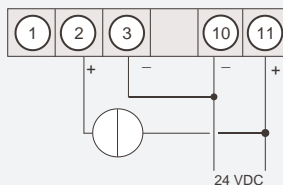

M1 in combination with a 3-wire sensor 0/4-20 mA

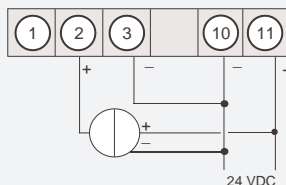

M1 in combination with a 3-wire sensor 0-10 V

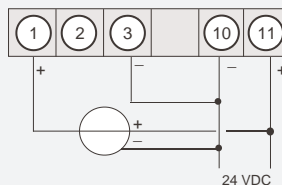

2-wire sensor 4-20 mA

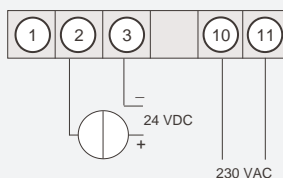

3-wire sensor 0/4-20 mA

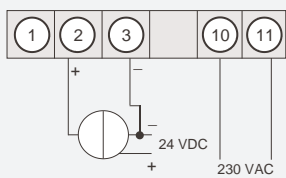

3-wire sensor 0-10 V

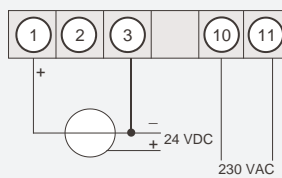

Dimensions

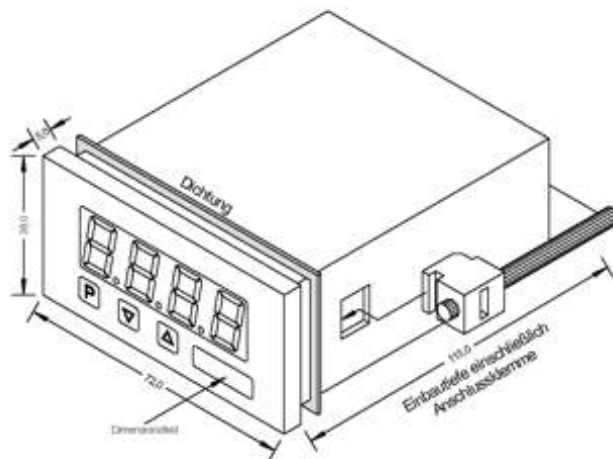

DIGITAL PANEL INSTRUMENTS

Ordering code M1-Standard 72 X 36 mm

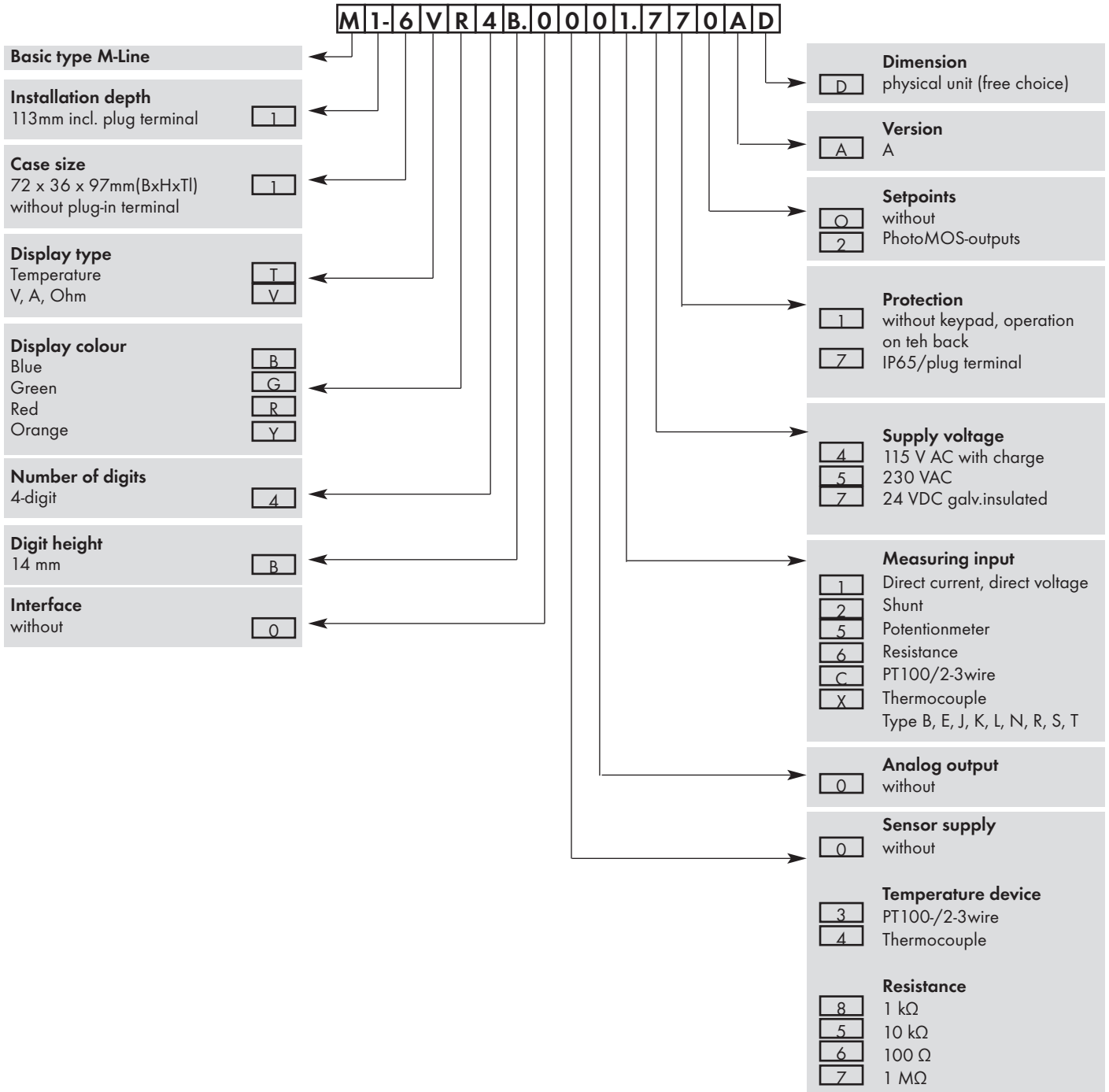

OPTIONS

Availability

Blue LED	●
Orange LED	●
Green LED	●

Technical Data			
Dimensions			
	Case	B72 x H36 x D97 mm, (including plug-in terminal D=113 mm)	
	Panel cut-out	68.0 +0.7 x 33.0 +0.6 mm	
	Fixing	Screw elements for insulation thickness up to 3 mm	
	Case material	PC Polycarbonate, black	
	Sealing material	EPDM, 65 Shore, black	
	Protection class	At the front IP65 Standard	
		Backside IP00	
	Weight	Approx. 200 g	
	Connection	Plug-in terminal; line cross-section up to 2.5 mm ²	
Display			
	Display	4-digit	
	Digit height	14 mm	
	Segment colour	Red (standard), optional available in green, blue and orange	
	Display range	-1999 to 9999	
	Setpoints	Optical display flashing	
	Overflow/Underflow	Horizontal bars at the top/ horizontal bars at the bottom	
	Display time/Measuring time	0.1 to 10.0 seconds	
Measuring input			
M1-6VR4B.0001...	Span	-12 ...12 V	/-22 ...24 mA
Direct current/	Measuring range	0-10 VDC	/0/4-20 mA
Direct voltage	Input resistance	Ri with ~200 kΩ	Ri with ~100 Ω
	Measuring error	0.1% of measuring range, +/- 1 Digit	/0.1% of measuring range, +/- 1 Digit
	Temperature drift	100ppm/K	
	Measuring time/principle	0.1 ...10.0 seconds/ U/F-conversion	
	Resolution	Approx. 18Bit at 1s measuring time	
Measuring input			
M1-6VR4B.0002...	Span	-5 ...80 mV	/-10 ...180 mV
Shunt	Measuring range	0 ...60 mV	/0 ...150 mV
	Input resistance	Ri at ~12 kΩ	Ri at ~30 kΩ
	Measuring error	0.2% of measuring range, +/- 1 Digit	/0.2% of measuring range, +/- 1 Digit
	Temperature drift	100ppm/K	
	Measuring time/principle	0.1 ...10.0 seconds/ U/F-conversion	
	Resolution	Approx. 18Bit at 1s measuring time	
Measuring input			
M1-6VR4B.0005...	Span	>1 kΩ ...1000 kΩ	
Potentiometer	Measuring range	0-100%	
	Measuring error	0.5% of measuring range, +/- 1 Digit	
	Temperature drift	100ppm/K	
	Measuring time/principle	0.1 ...10.0 seconds/ U/F-conversion	
	Resolution	Approx. 18Bit at 1s measuring time	
Measuring input			
M1-6VR4B.0x06...	Span	0...1,1 kΩ, 0...11 kΩ, 0...110 kΩ, 0...1100 kΩ	
Resistance	Measuring range	0...1kΩ, 0...10 kΩ, 0...100 kΩ, 0...1000 kΩ	
	Measuring error	0.1% of measuring range, +/- 1 Digit	
	Temperature drift	100ppm/K	
	Measuring time/principle	0.1 ...10.0 seconds/ U/F-conversion	
	Resolution	Approx. 18Bit at 1s measuring time	
Measuring input			
M1-6TR4B.030C...	Measuring range	-200 ...850 °C/ -328 ...1562 °F	
PT100	Measuring error	0.1% of measuring range, +/- 1 Digit	
	Temperature drift	100ppm/K	
	Measuring time/principle	0.1 ...10.0 seconds/ U/F-conversion	
	Resolution	Approx. 0.1 °C or 0.1 °F	
Measuring input			
M1-6VR4B.040X...	Measuring range	Type L -200...900 °C	Type B 80...1820 °C
Thermocouple		Type J -210...1200 °C	Type S -50...1768 °C
		Type K -270...1372 °C	Type T -270...400 °C
		Type N -270...1300 °C	Type R -50...1768 °C
	Measuring error	2K, +/- 1 Digit	
	Temperature drift	100ppm/K	
	Measuring time/principle	0.1 ...10.0 seconds/ U/F-conversion	
	Resolution	0.1 °C	
	Characteristic curve error	< +/- 1 kΩ	
	Reference junction	Thermistor	
Power pack			
	Supply	230 VAC +/- 10% (max. 6VA)	
		24 VDC +/- 10%, galvanic insulated (max.1 VA)	
Memory			
	EEPROM		
	Data life	≥ 100 years	
Ambient conditions			
	Working temperature	0 to +60 °C	
	Storing temperature	-20 to +80	
	Climatic density	Relative humidity 0-85% on years average without dew	

M1-3S...

Programmable Digital Panel Instrument M1-Current Loop, 96 x 24 mm



- Red display of -1999 up to 9999
- Minimal installation depth: 37 mm without plug terminal
- Min-/max-value recording
- Adjustment via factory default or directly on the sensor signal
- Display flashing at threshold exceedance / undershooting
- Tara- / offset value calibration
- 10 adjustable setpoints
- Programming interlock via access code
- Protection class IP65
- Plug terminal

M1-3S
Case 96 x 24 mm



EMV EN 61326
CE-sign Conformity to 2004/108/EG
Safety standard EN 61010

General Technical Data, Type M1-3S

Case	B96 x H24 x D37 mm, (incl. Plug terminal D = 63 mm)
Panel cut-out	92.0 +0.8 x 22.2 +0.3 mm
Fixing	Screw elements for insulation thickness up to 3 mm
Case material	PC, black colour, Polycarbonate
Protection class	Front IP65 standard Rearside IP00
Weight	Approx. 100 g
Connection	Plug terminal; line cross section up to 2.5mm ²
Digit height/ Segment Colour	14mm/red
Display range	-1999 to 9999
Switchpoint	Optical display flashing
Display/measuring time	0.1 to 0.0 seconds
Input	Min. 3.5 ...max. 21mA (4-20mA)
Measuring error	0.3%v. of measuring range, +- 1 digit
Fail of voltage	Approx. 5.1 V without switching outputs Approx. 8.0 V with switching outputs
Setpoints	Potentialfree PhotoMOS-outputs Max. switching voltage 30 VDC/AC Max. steady current 0,4 A Electric strength AC: 400 V permanent, 1800 V for 1 minute
Data life	> 100 years Flash-memory (independent of supply)
Working/Storing temperature	0 to 60°C (-20 to +80°C)
Climatic density	Relative humidity 0-80% on years average without dew

Current loop device

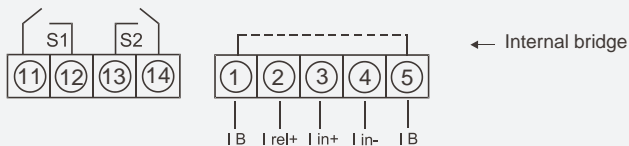
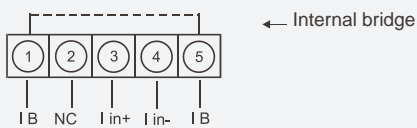

Outputs; at interfere with switching outputs using measuring input Irel., please.

Order number (without options)

M1-3SR4B.0001.K70AD

M1-3SR4B.0001.K72AD

Connection pictures

Current loop display in combination with a transmitter in current loop technique:

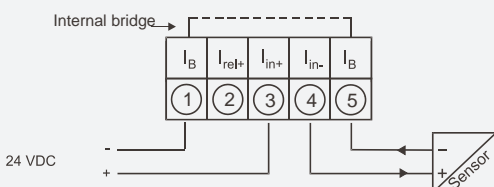

Current loop display in combination with another measuringout with low burden:

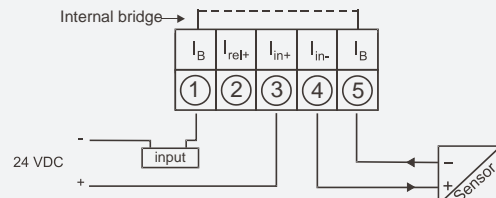

Current loop device in combination with a 3-/4 wire sensor:

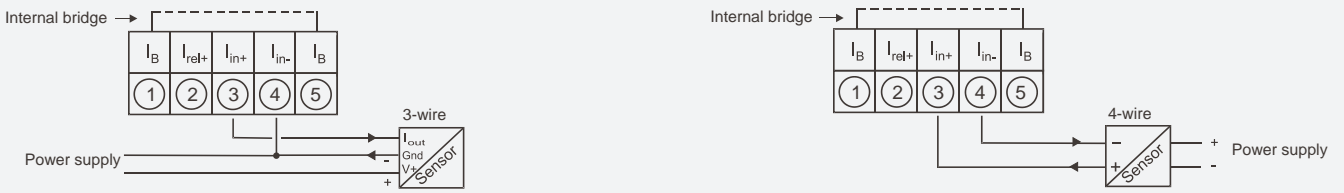

Current loop device with enable outputs 24 V DC (up to 0.4 A):

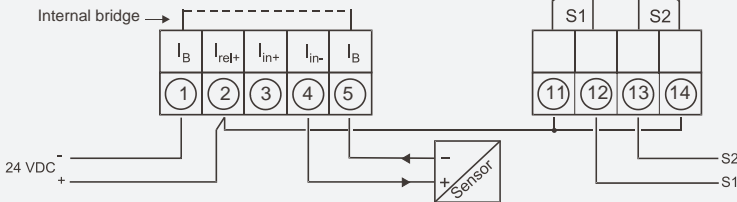

Dimensions

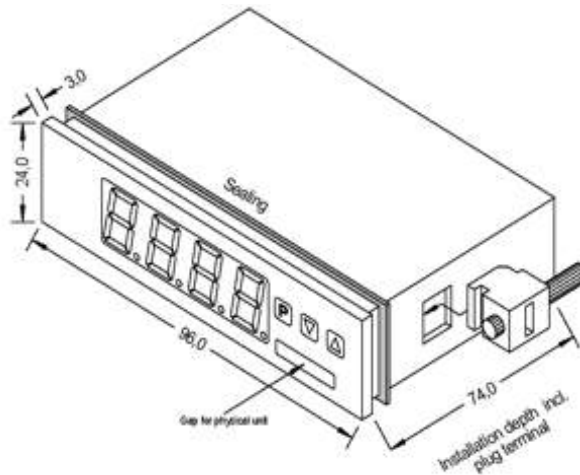

Ordering code M1-Current Loop 96 x 24 mm

M1-3SR4B.0001.K70AD		
Basic type M-Line	← M	
Installation depth 63mm incl. plug-in terminal	← 1	D Dimension physical unit
Case size 96 x 24 x 37 mm without plug-in terminal	← 3	A Version A
Display type Current loop	← S	0 Setpoints without Photo MOS-outputs 2 Setpoints with Photo MOS-outputs
Display colour Red	← R	7 Protection IP65/plug terminal
Number of digits 4-digit	← 4	K Supply voltage via current
Digit height 14 mm	← B	1 Measuring input Direct current 4-20 mA
Interface without	← 0	0 Analog output without
		0 Sensor supply without

M1-3V.../ M1-3T



Programmable Digital Panel Instrument 96 x 24 mm



- Red display of -1999 up to 9999 (optional green, orange or blue display)
- Minimal installation depth: 57 mm without plug-in terminal
- Min-/max-value recording
- 10 adjustable setpoints
- Display flashing at threshold exceedance / undershooting
- Tara-function
- Programming interlock via access code
- Protection class IP65 at the front
- Plug-in terminal
- Adjustment via factory default or directly on the sensor signal

M1-3V

Case 96 X 24 mm



EMV EN 61326

CE-Sign Conformity to 2004/108/EG

Safety EN 61010

Direct current, direct voltage

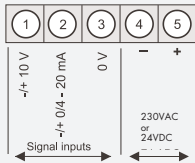

Supply	Order number (without options)
230V AC	M1-3VR4B.0001.570AD
24V DC	M1-3VR4B.0001.770AD

Direct voltage (Shunt)

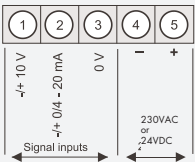

Supply	Order number (without options)
230V AC	M1-3VR4B.0002.570AD
24V DC	M1-3VR4B.0002.770AD

Potentiometer 0-100 % (1 kΩ ...100 kΩ)

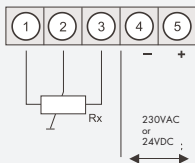

Supply	Order number (without options)
230V AC	M1-3VR4B.0005.570AD
24V DC	M1-3VR4B.0005.770AD

Resistance (1kΩ, 10kΩ, 100kΩ or 1000kΩ)

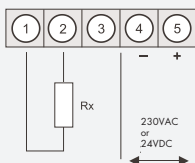

Supply	Order number (without options)
230V AC	(Measuring range 1 kΩ) M1-3VR4B.0806.570AD
24 V DC	(Measuring range 1 kΩ) M1-3VR4B.0806.770AD
230V AC	(Measuring range 10 kΩ) M1-3VR4B.0506.570AD
24 V DC	(Measuring range 10 kΩ) M1-3VR4B.0506.770AD
230V AC	(Measuring range 100 kΩ) M1-3VR4B.0606.570AD
24 V DC	(Measuring range 100 kΩ) M1-3VR4B.0606.770AD
230V AC	(Measuring range 1000 kΩ) M1-3VR4B.0706.570AD
24 V DC	(Measuring range 1000 MΩ) M1-3VR4B.0706.770AD

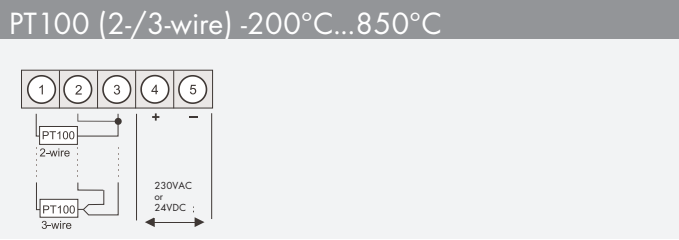

Supply	Order number (without options)
230V AC	M1-3TR4B.030C.570AD
24V DC	M1-3TR4B.030C.770AD

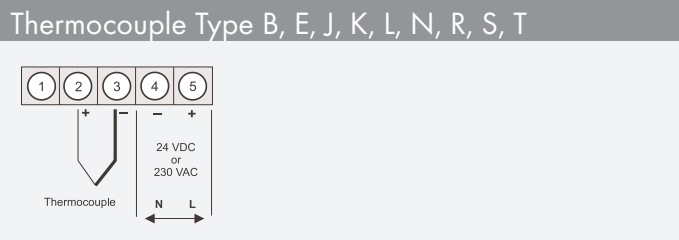

Supply	Order number (without options)
230V AC	M1-3TR4B.040X1.570AD
24V DC	M1-3TR4B.040X1.770AD

OPTIONS	Availability
Blue LED	●
Orange LED	●
Green LED	●

Connection examples

M1 devices with direct current/ direct voltage input

M1 in combination with a 2-wire sensor of 4-20 mA

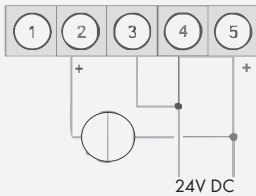

M1 in combination with a 3-wire sensor of 0/4-20 mA

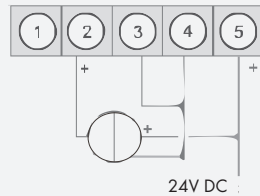

M1 in combination with a 3-wire sensor of 0-10 V

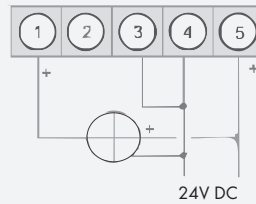

Dimensions

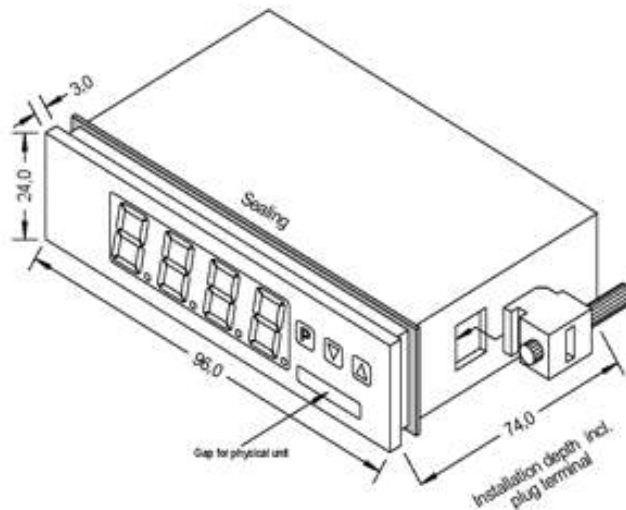

DIGITAL PANEL INSTRUMENTS

Ordering code M1-Standard 48 x 24 mm

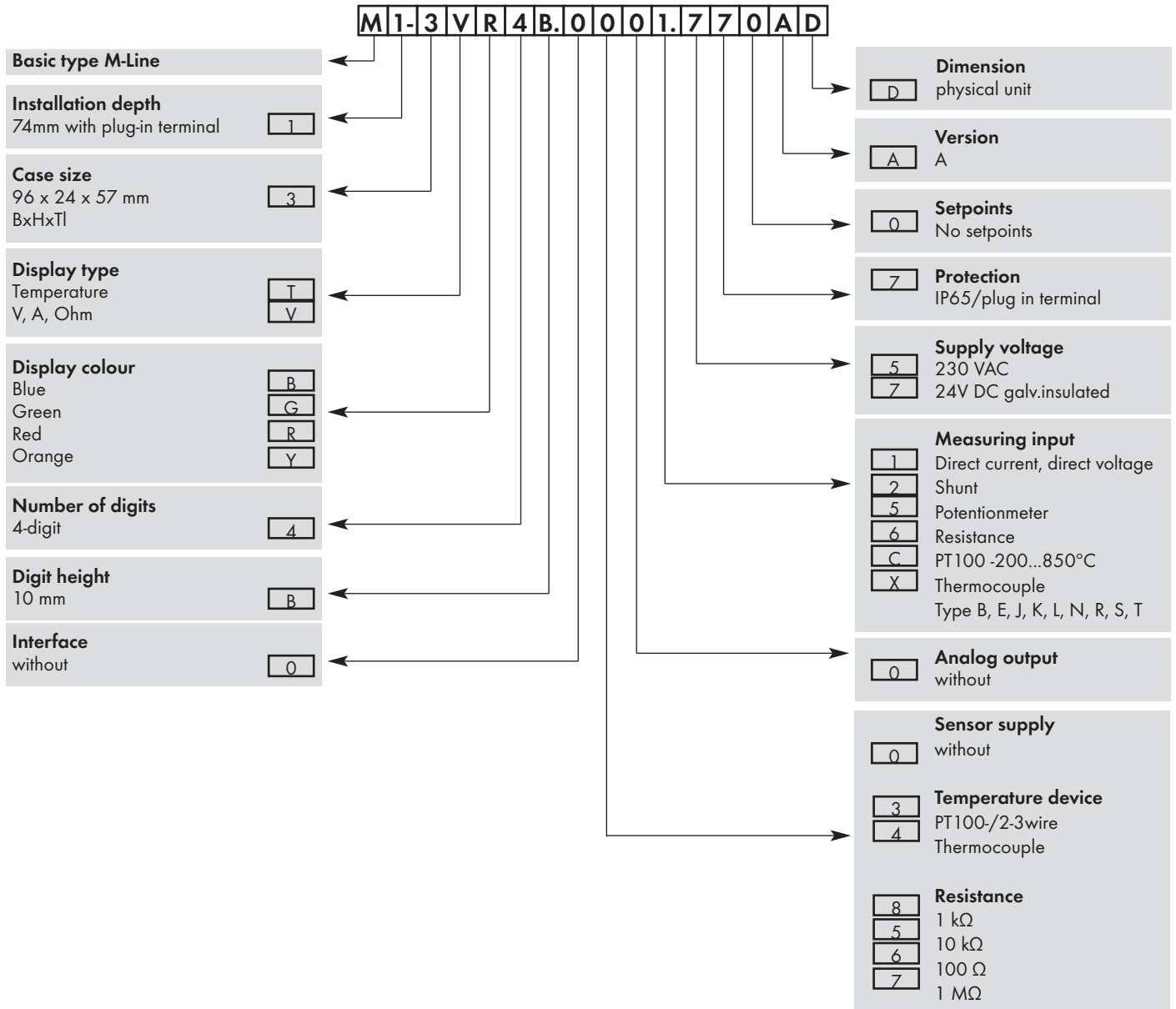

Technical Data			
Dimensions			
Case	B96 x H24 x D57 mm, (including plug-in terminal D=74 mm)		
Panel cut-out	92.0 +0,8 x 22.2 +0,3 mm		
Fixing	Screw elements for insulation thickness up to 3 mm		
Case material	PC Polycarbonate, black		
Sealing material	EPDM, 65 Shore, black		
Protection class	At the front IP65 Standard Backside IP00		
Weight	Approx. 50 g		
Connection	Plug-in terminal; line cross-section up to 2.5 mm ²		
Display			
Display	4-digit		
Digit height	14 mm		
Segment colour	Red (standard), optional available in green, blue and orange		
Display range	-1999 to 9999		
Setpoints	Optical display flashing		
Overflow/Underflow	Horizontal bars at the top/ horizontal bars at the bottom		
Display time/Measuring time	0.1 to 10.0 seconds		
Measuring input			
M1-3VR4B.0001... Direct current/ Direct voltage	Span	-12 ...12 V /-22 ...24 mA	
	Measuring range	0 -10 V /0/4-20 mA	
	Input resistance	Ri at ~200 kΩ Ri at ~100 Ω	
	Measuring error	0.1% of measuring range, +/- 1 Digit /0.1% of measuring range, +/- 1 Digit	
	Temperature drift	100ppm/K	
	Measuring time/principle	0.1 ...10.0 seconds/ U/F-conversion	
	Resolution	Approx. 18Bit at 1s measuring time	
Measuring input			
M1-3VR4B.0002... Shunt	Span	-5 ...80 mV /-10 ...180 mV	
	Measuring range	0 ...60 mV /0 ...150 mV	
	Input resistance	Ri at ~12 kΩ Ri at ~30 kΩ	
	Measuring error	0.2% of measuring range, +/- 1 Digit /0.2% of measuring range, +/- 1 Digit	
	Temperature drift	100ppm/K	
	Measuring time/principle	0.1 ...10.0 seconds/ U/F-conversion	
	Resolution	Approx. 18Bit at 1s measuring time	
Measuring input			
M1-3VR4B.0005... Potentiometer	Span	>1 kΩ ...1000 kΩ	
	Measuring range	0-100%	
	Measuring error	0.1% of measuring range, +/- 1 Digit	
	Temperature drift	100ppm/K	
	Measuring time/principle	0.1 ...10.0 seconds/ U/F-conversion	
	Resolution	Approx. 18Bit at 1s measuring time	
Measuring input			
M1-3VR4B.0x06... Resistance	Span	0...1,1 kΩ, 0...11 kΩ, 0...110 kΩ, 0...1100 kΩ	
	Measuring range	0...1kΩ, 0...10 kΩ, 0...100 kΩ, 0...1000 kΩ	
	Measuring error	0.5% of measuring range, +/- 1 Digit	
	Temperature drift	100ppm/K	
	Measuring time/principle	0.1 ...10.0 seconds/ U/F-conversion	
	Resolution	Approx. 18Bit at 1s measuring time	
Measuring input			
M1-3TR4B.030C... PT100	Measuring range	-200 ...850 °C/ -328 ...1562 °F	
	Measuring error	0.2% of measuring range, +/- 1 Digit	
	Temperature drift	100ppm/K	
	Measuring time/principle	0.1 ...10.0 seconds/ U/F-conversion	
	Resolution	Approx. 0.1 °C or 0.1 °F	
Measuring input			
M1-3TR4B.040X... Thermocouple	Measuring range	Type L -200...900 °C	Type B 80...1820 °C
		Type J -210...1200 °C	Type S -50...1768 °C
		Type K -270...1372 °C	Type N -270...1300 °C
		Type E -270... 1000 °C	Type T -270...400 °C
		Type R -50...1768 °C	
	Measuring error	2K, +/- 1 Digit	
	Temperature drift	100ppm/K	
	Measuring time/principle	0.1 ...10.0 seconds/ U/F-conversion	
	Resolution	0.1 °C	
	Characteristic curve error	> +/- 1 kΩ	
	Reference junction	Semiconductor sensor	
Power pack			
	Supply	230 VAC +/- 10% (max. 9 VA) 24 VDC +/- 10%, galvanic insulated (max.1 VA)	
Memory			
	EEPROM		
	Data life	≥ 100 years	
Ambient conditions			
	Working temperature	0 up to +60 °C	
	Storing temperature	-20 up to +80 °C	
	Climatic density	Relative humidity 0-85% on years average without dew	

M1-1S...

Programmable Digital Panel M1-Current Loop, 96 x 48 mm



- Red display of -1999 up to 9999
- Minimal installation depth: 25 mm without plug-in terminal
- Min-/max-value recording
- Adjustment via factory default or directly on the sensor signal
- Display flashing at threshold exceedance / undershooting
- Tara- / offset value calibration
- 10 adjustable setpoints
- Programming interlock via access code
- Protection class IP65
- Plug-in terminal

General Technical Data, Type M1-1S

Case	B96 x H48 x D25 mm, (incl. Plug terminal D = 38 mm)
Panel cut-out	92.0 ^{+0.8} x 45.0 ^{+0.6} mm
Fixing	Screw elements for insulation thickness up to 3 mm
Case material	PC, Polycarbonate, black
Protection class	Front IP65 standard Rearside IP00
Weight	Approx. 100 g
Connection	Plug terminal; line cross section up to 2.5mm ²
Digit height/ Segment Colour	14mm/red
Display range	-1999 to 9999
Setpoints	Optical display flashing
Display/measuring time	0.1 to 0.0 seconds
Input	Min. 3.5 ...max. 21 mA (4-20mA)
Measuring error	0.3% of measuring range, + - 1 digit
Fail of voltage	Approx. 5.1 V without switching outputs Approx. 8.0 V with switching outputs
Setpoints	Potentialfree PhotoMOS-outputs Max. switching voltage 30 VDC/AC Max. steady current 0,4 A Electric strength AC: 400 V permanent, 1800 V for 1 minute
Data life	≥ 100 years Flash-memory (independent of supply)
Working/Storing temperature	0 to 60°C (-20 to +80°C)
Climatic density	Relative humidity 0-80% on years average without dew

M1-1S
Case 96 x 48 mm



EMV EN 61326
CE-sign Conformity to 2004/108/EG
Safety standard EN 61010

Current loop device

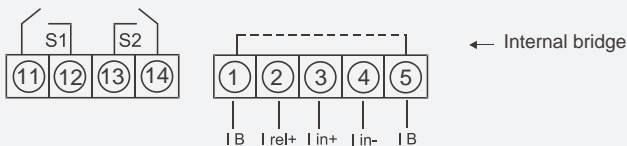
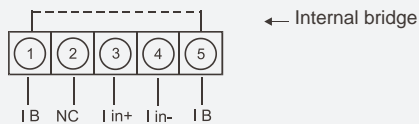

Outputs; at interfere with switching outputs using measuring input Irel., please.

Order number (without options)

M1-1SR4B.0001.K70AD

M1-1SR4B.0001.K72AD

Connection pictures (our examples show devices with setpoints)

Current loop display in combination with a transmitter in current loop technique:

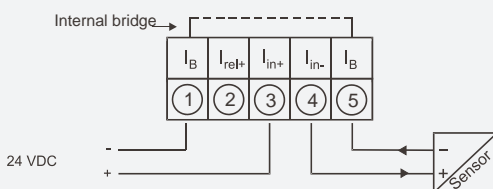

Current loop display in combination with another measuringout with low burden:

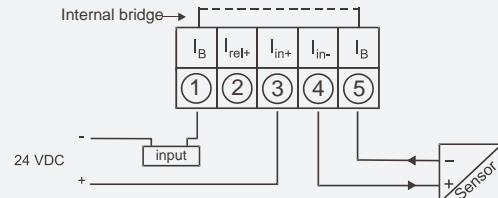

Current loop device in combination with a 3-/4 wire sensor:

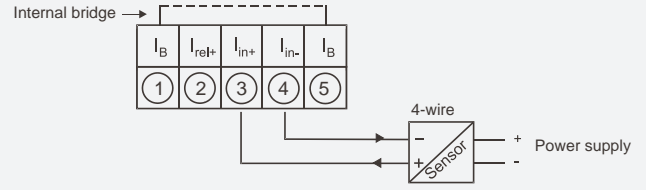
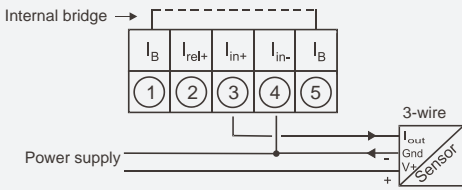

Current loop device with enable outputs 24 V DC (up to 0.4 A):

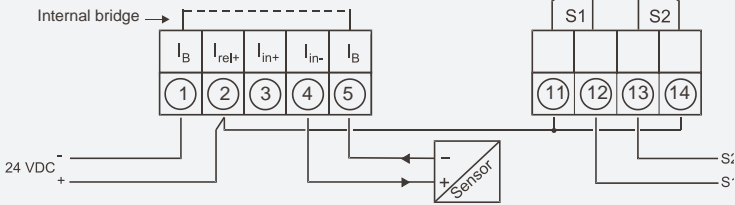

Dimensions

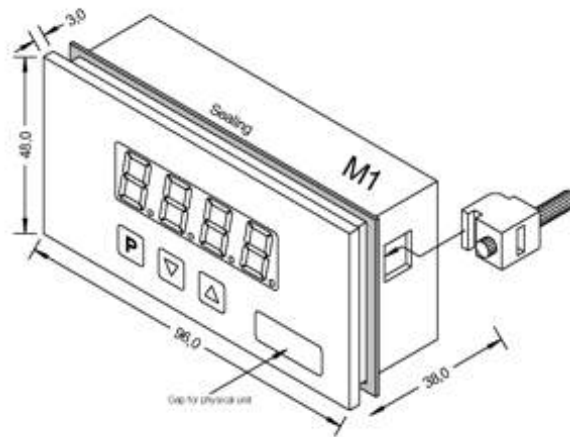

Ordering code M1-Current Loop 96 x 48 mm

Basic type M-Line		M1-1SR4B.0001.K70AD												
Installation depth 38mm incl. plug-in terminal	1	1	1	1	1	1	1	1	1	1	1	1	D	Dimension physical unit
Case size 96 x 48 x 25 mm without plug-in terminal	3	3	3	3	3	3	3	3	3	3	3	3	A	Version A
Display type Current loop	S	S	S	S	S	S	S	S	S	S	S	S	0 2	Setpoints without Photo MOS-outputs
Display colour Red	R	R	R	R	R	R	R	R	R	R	R	R	7	Protection IP65/plug terminal
Number of digits 4-digit	4	4	4	4	4	4	4	4	4	4	4	4	K	Supply voltage via current
Digit height 14 mm	B	B	B	B	B	B	B	B	B	B	B	B	1	Measuring input Direct current 4-20 mA
Interface without	0	0	0	0	0	0	0	0	0	0	0	0	0	Analog output without
													0	Sensor supply without

M1-1V.../ M1-1T...



Programmable Digital Panel 96 x 48 mm



- Red display of -1999 up to 9999 (optional green, orange or blue display)
- Minimal installation depth: 25 mm without plug-in terminal
- Min-/max-value recording
- 10 adjustable setpoints
- Display flashing at threshold exceedance / undershooting
- Tara-function
- Adjustment via factory default or directly on the sensor signal
- Programming interlock via access code
- Protection class IP65
- Plug-in terminal

M1-1V

Case 96 X 48 mm



EMV EN 61010

CE-Sign Conformity to 2004/108/EG

Safety EN 61326

Direct current, direct voltage

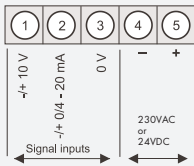

Supply	Order number (without options)
230 V AC	M1-1VR4B.0001.570BD
24V DC	M1-1VR4B.0001.770BD Further supply voltage see options

Direct voltage (Shunt)

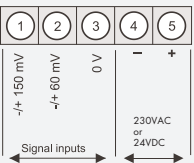

Supply	Order number (without options)
230 V AC	M1-1VR4B.0002.570BD
24V DC	M1-1VR4B.0002.770BD

Potentionmeter 0-100 % (1 kΩ ... 100 kΩ)

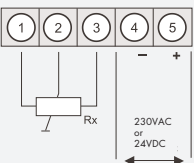

Supply	Order number (without options)
230 V AC	M1-1VR4B.0005.570BD
24V DC	M1-1VR4B.0005.770BD

Resistance (1kΩ, 10kΩ, 100kΩ or 1000kΩ)

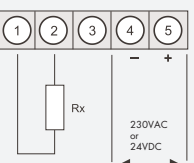

Supply	Order number (without options)
230V AC	(Measuring range 1 kΩ) M1-1VR4B.0806.570BD
24 V DC	(Measuring range 1 kΩ) M1-1VR4B.0806.770BD
230V AC	(Measuring range 10 kΩ) M1-1VR4B.0506.570BD
24 V DC	(Measuring range 10 MΩ) M1-1VR4B.0506.770BD
230V AC	(Measuring range 100 kΩ) M1-1VR4B.0606.570BD
24 V DC	(Measuring range 100 kΩ) M1-1VR4B.0606.770BD
230V AC	(Measuring range 1000 kΩ) M1-1VR4B.0706.570BD
24 V DC	(Measuring range 1000 MΩ) M1-1VR4B.0706.770BD

PT100 (2-/3-wire) -200°C...850°C/-328°F...1562°F

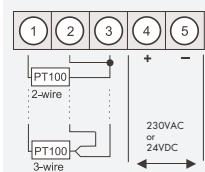

Supply	Order number (without options)
230 V AC	M1-1TR4B.030C.570BD
24V DC	M1-1TR4B.030C.770BD

PT1000 (2-wire) -200°C...850°C/-328°F...1562°F

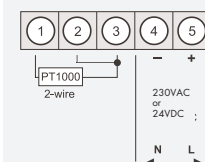

Supply	Order number (without options)
230 V AC	M1-1TR4B.060C.570BD
24V DC	M1-1TR4A.060C.770BD

Thermocouple Type B, E, J, K, L, N, R, S, T

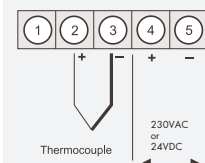

Supply	Order number (without options)
230 V AC	M1-1TR4B.040X.570BD
24V DC	M1-1TR4B.040X.770BD

Connection examples

M1 devices with direct current / direct voltage input

M1 in combination with a 2-wire-sensor 4-20 mA

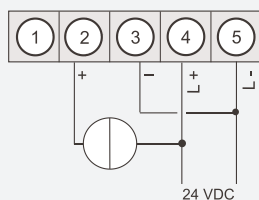

M1 in combination with a 3-wire-sensor 0/4-20 mA

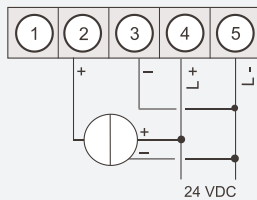

M1 in combination with a 3-wire-sensor 0-10 V

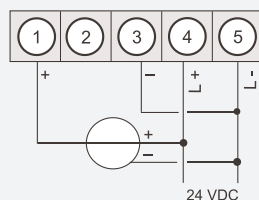

Dimensions

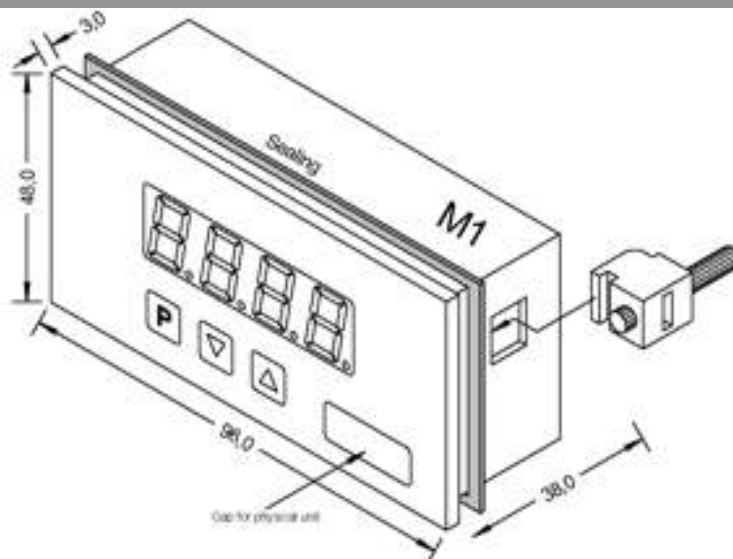

DIGITAL PANEL INSTRUMENTS

Ordering code M1-Standard 96 x 48 mm

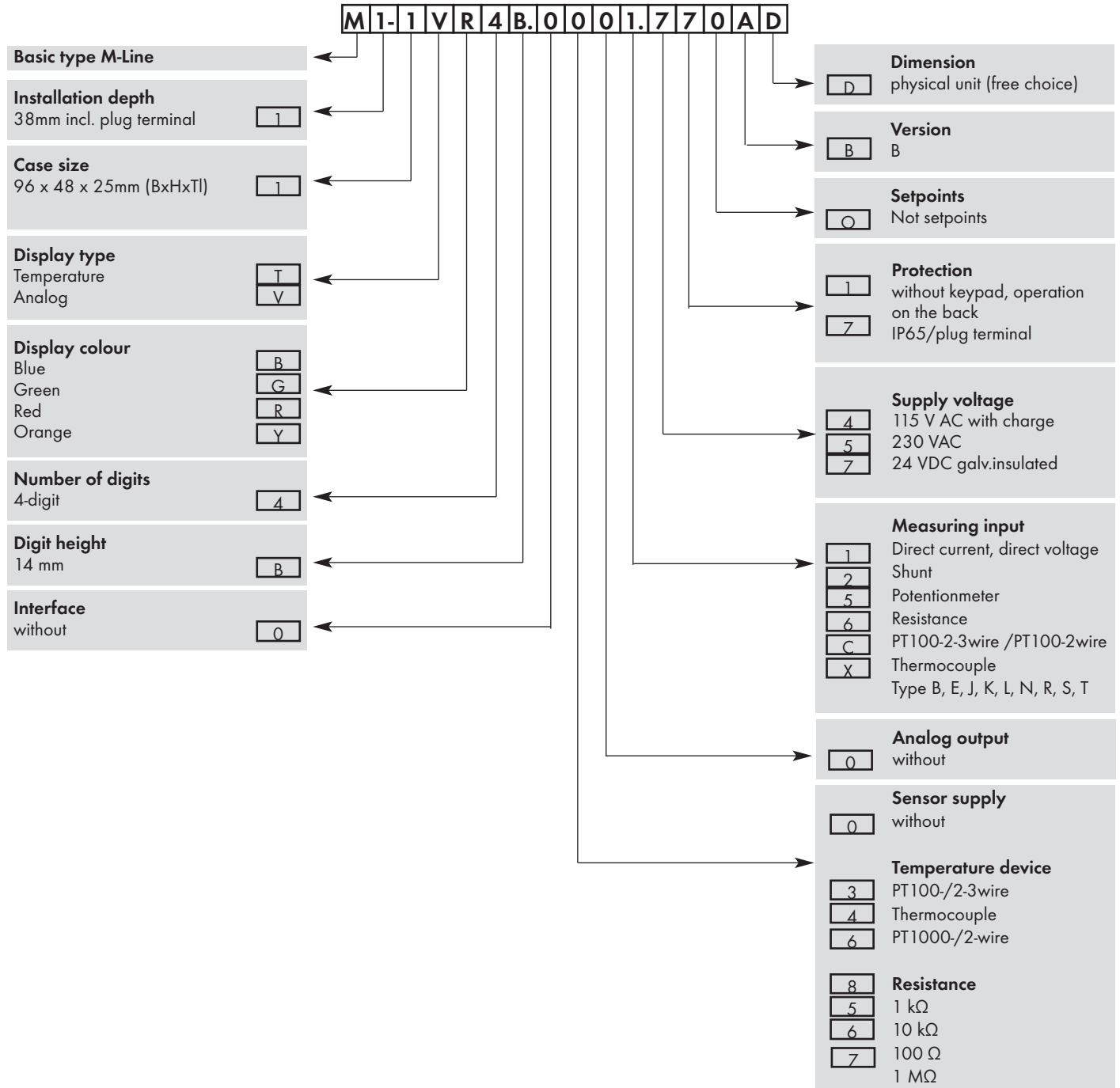

OPTIONS

Availability

OPTIONS	Availability
Blue LED	●
Orange LED	●
Green LED	●
S260 measuring input up to 50 VDC / measuring error 0.6% of final value	●
S100 measuring input up to 100 VDC / measuring error 0.6 % of final value	●

Technical Data

Dimensions

Case	B96 x H48 x D25 mm, (including plug-in terminal D=38 mm)
Panel cut-out	92.0 +0.8 x 45.0 +0.6 mm
Fixing	Screw elements for insulation thickness up to 3 mm
Case material	PC Polycarbonate, black
Sealing material	EPDM, 65 Shore, black
Protection class	At the front IP65 Standard Backside IP00
Weight	Approx. 100 g
Connection	Plug-in terminal; line cross-section up to 2.5 mm ²

Display

Display	4-digit
Digit height	14 mm
Segment colour	Red (standard), optional available in green, blue and orange
Display range	-1999 to 9999
Setpoints	Optical display flashing
Overflow/Underflow	Horizontal bars at the top/ horizontal bars at the bottom
Display time/Measuring time	0.1 to 10.0 seconds

Measuring input

M1-1VR4B.0001... Direct current/ Direct voltage	Span Measuring range Input resistance Measuring error Temperature drift Measuring time/principle Resolution	-12 ...12 V 0-10 VDC Ri at ~200 kΩ 0.1% of measuring range, +/- 1 Digit 100ppm/K 0.1 ...10.0 seconds/ U/F-conversion Approx. 18Bit at 1s measuring time	/-22 ...24 mA /0/4-20 mA Ri at ~100 Ω /0.1% of measuring range, +/- 1 Digit
---	---	---	--

Measuring input

M1-1VR4B.0002... Shunt	Span Measuring range Input resistance Measuring error Temperature drift Measuring time/principle Resolution	-5 ...80 mV 0 ...60 mV Ri at ~12 kΩ 0.2% of measuring range, +/- 1 Digit 100ppm/K 0.1 ...10.0 seconds/ U/F-conversion Approx. 18Bit at 1s measuring time	/-10 ...180 mV /0 ...150 mV Ri at ~30 kΩ /0.2% of measuring range, +/- 1 Digit
---------------------------	---	--	---

Measuring input

M1-1VR4B.0005... Potentionmeter	Span Measuring range Measuring error Temperature drift Measuring time/principle Resolution	>1 kΩ ...1000 kΩ 0-100% 0.5% of measuring range, +/- 1 Digit 100ppm/K 0.1 ...10.0 seconds/ U/F-conversion Approx. 18Bit at 1s measuring time
------------------------------------	---	---

Measuring input

M1-1VR4B.0x06... Resistance	Span Measuring range Measuring error Temperature drift Measuring time/principle Resolution	0...1,1 kΩ, 0...11 kΩ, 0...110 kΩ, 0...1100 kΩ 0...1kΩ, 0...10 kΩ, 0...100 kΩ, 0...1000 kΩ 0.1% of measuring range, +/- 1 Digit 100ppm/K 0.1 ...10.0 seconds/ U/F-conversion Approx. 18Bit at 1s measuring time
--------------------------------	---	--

Measuring input

M1-1TR4B.030C... PT100	Measuring range Measuring error Temperature drift Measuring time/principle Resolution	-200 ...850 °C/ -328 ...1562 °F 0.1% of measuring range, +/- 1 Digit 100ppm/K 0.1 ...10.0 seconds/ U/F-conversion Approx. 0.1 °C or 0.1 °F
---------------------------	---	--

Measuring input

M1-1TR4B.060C... PT1000	Measuring range Measuring error Temperature drift Measuring time/principle Resolution	-200 ...850 °C/ -328 ...1562 °F 0.2% of measuring range, +/- 1 Digit 100ppm/K 0.1 ...10.0 seconds/ U/F-conversion Approx. 0.1 °C or 0.1 °F
----------------------------	---	--

Measuring input

M1-3TR4B.040X... Thermocouple	Measuring range Measuring error Temperature drift Measuring time/principle Resolution Characteristic curve error Reference junction	Type L -200...900 °C Type J -210...1200 °C Type K -270...1372 °C 2K, +/- 1 Digit 100ppm/K 0.1 ...10.0 seconds/ U/F-conversion 0.1 °C ≤ +/- 1 kΩ Semiconductor sensor	Type B 80...1820 °C Type S -50...1768 °C Type N -270...1300 °C	Type E -270... 1000 °C Type T -270...400 °C Type R -50...1768 °C
----------------------------------	---	--	--	--

Power pack

Supply	230 VAC +/- 10% (max. 9 VA) 24 VDC +/- 10%, galvanic insulated (max.1 VA)
--------	--

Memory

EEPROM Data life	≥ 100 years
---------------------	-------------

Ambient conditions

Working temperature	0 to +60 °C
Storing temperature	-20 to +80
Climatic density	Relative humidity 0-85% on years average without dew

M2-1V.../ M2-1T...



Programmable Digital Panel 96 x 48 mm



- Red display of -1999 up to 99999 (optional green, orange, blue or tricolour display)
- Minimal installation depth: 70 mm without plug-in terminal
- Min-/max-memory
- 30 additional adjustable setpoints (parameter driven)
- Display flashing at threshold exceedance / undercut
- Zero key for actuation of tara- /hold-function
- Permanent min-/max-value recording
- Adjustment via factory default or directly on the sensor signal
- Volume measurement (totalizer)
- mathematical functions like reciprocal value, square root, square and rounding
- Programming interlock via access code
- Protection class IP65 at the front
- Plug-in terminal
- Two relay outputs optional
- Analog output or sensor supply optional
- Digital input optional

M2-1V.../ M2-1T...
Case 96 x 48 mm



Direct current, direct voltage

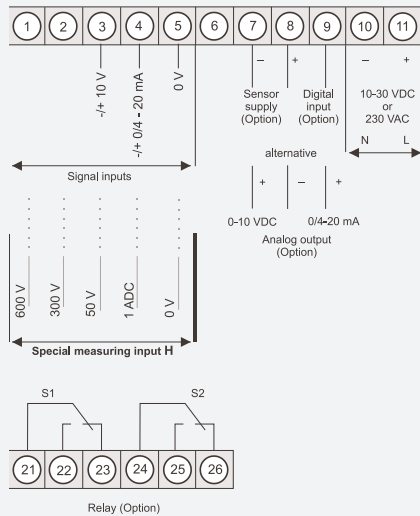

Supply

230 VAC
10 - 30 VDC

Order number (without options)

M2-1VR5B.0001.570BD
M2-1VR5B.0001.670BD

230 VAC
Special measuring input:

M2-1VR5B.0H01.570BD
600V, 300V, 50V, 1 A AC

Direct voltage (Shunt)

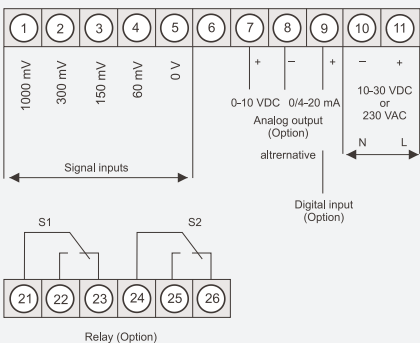

Supply

230 VAC
10 - 30 VDC

Order number (without options)

M2-1VR5B.0002.570BD
M2-1VR5B.0002.670BD

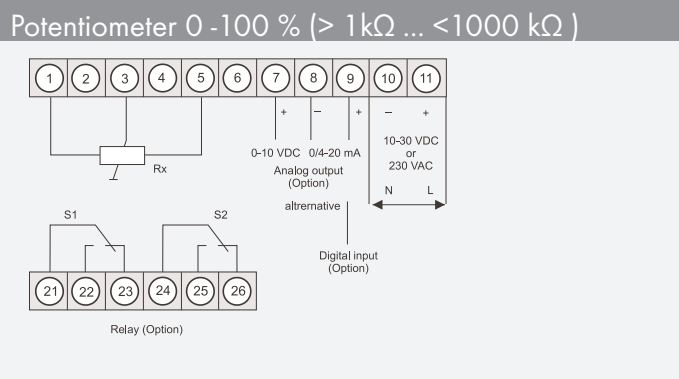

Supply	Order number (without options)
230 VAC 10 - 30 VDC	M2-1VR5B.0005.570BD M2-1VR5B.0005.670BD

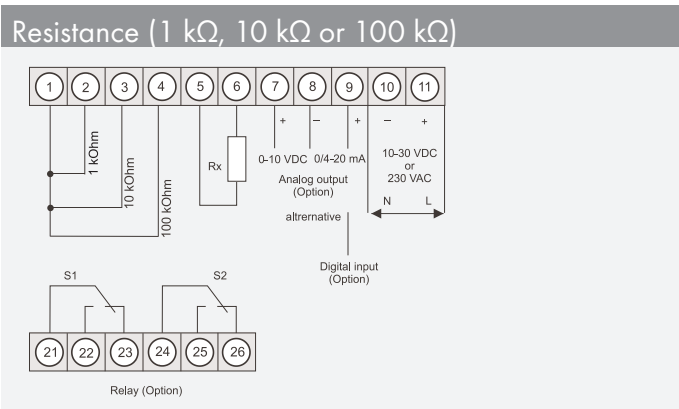

Supply	Order number (without options)
230 VAC 10 - 30 VDC	M2-1VR5B.0006.570BD M2-1VR5B.0006.670BD

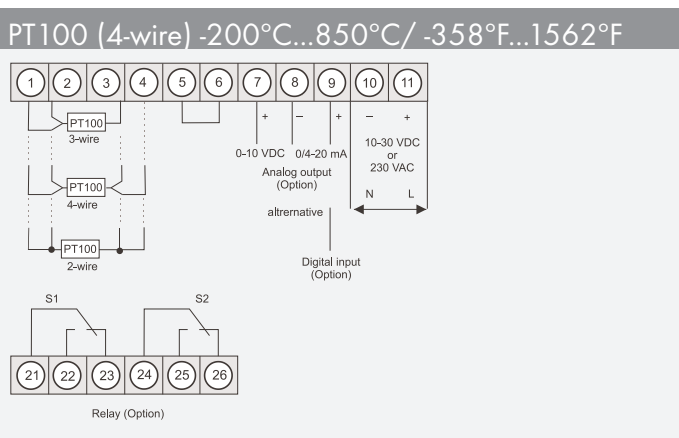

Supply	Order number (without options)
230 VAC 10 - 30 VDC	M2-1VR5B.010C.570BD M2-1VR5B.010C.670BD
230 VAC 10 - 30 VDC Special measuring input:	M2-1VR5B.020C.570BD M2-1VR5B.020C.670BD PT100-2-wire

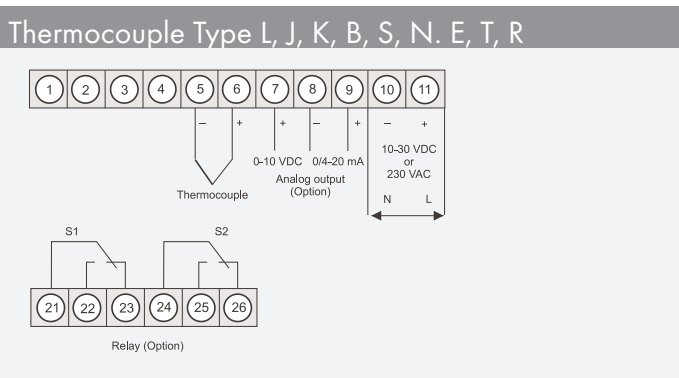

Supply	Order number (without options)
230 VAC 10 - 30 VDC	M2-1TR5B.040X.570BD M2-1TR5B.040X.670BD

DIGITAL PANEL INSTRUMENTS

Frequency (0,01 Hz to 999,99 Hz)

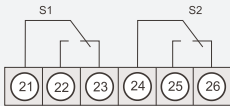
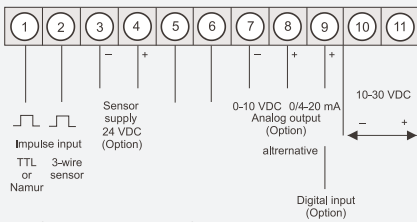
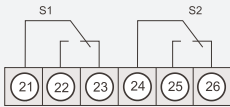
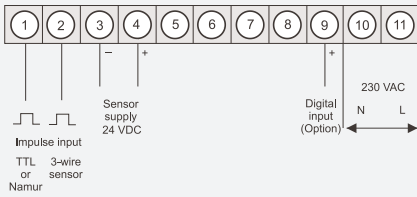

Supply	Order number (without options)
230 VAC	M2-1FR5B.0007.570BD
10 - 30 VDC	M2-1FR5B.0007.670BD

AC voltage, alternating current (true RMS)

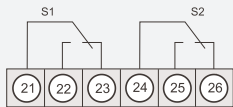
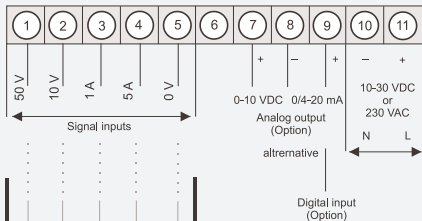

Supply	Order number (without options)
230 VAC 10 - 30 VDC	M2-1VR5B.0004.570BD M2-1VR5B.0004.670BD
230 VAC Special measuring input:	M2-1VR5B.0H04.570BD 600V, 300V, 5A, 1 AC

DMS 4-wire with calibration

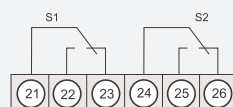
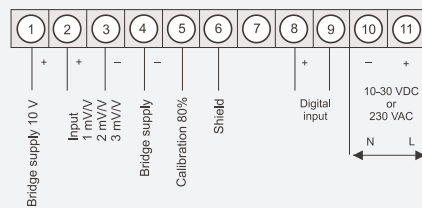

Supply	Order number (without options)
230 VAC 10 - 30 VDC	M2-1MR5B.020X.570BD M2-1MR5B.020X.670BD

Weighing technology

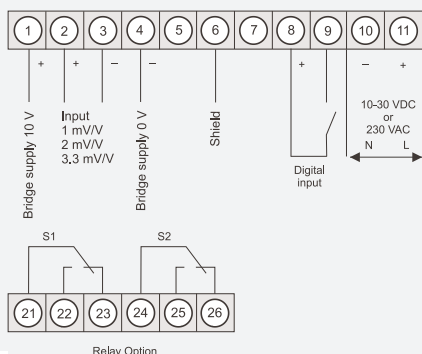

Supply	Order number (without options)
230 VAC 10 - 30 VDC	M2-1WR5B.020X.570BD M2-1WR5B.020X.670BD

OPTIONS

Availability

	<i>Direct current/-voltage</i>	<i>H Direct current/-voltage</i>	<i>Shunt</i>	<i>Potentiometer</i>	<i>Resistance</i>	<i>PT100</i>	<i>Thermo couple</i>	<i>Frequency</i>	<i>AC-RMS</i>	<i>DMS-4-wire</i>	<i>Weighing technology</i>
Blue LED	●	●	●	●	●	●	●	●	●	●	●
Orange LED	●	●	●	●	●	●	●	●	●	●	●
Green LED	●	●	●	●	●	●	●	●	●	●	●
Tricolour (red-green-orange)		●	●	●	●	●	●	●	●	●	●
Digital input		●	●	●	●			●	●	●	●
Sensor supply 24 VDC / 50 mA at a device supply of 230 VAC		●									
Sensor supply 24 VDC / 50 mA at a device supply of 24 VDC		●						●			
Sensor supply 10 VDC / 50 mA at a device supply of 230 VAC		●						●			
Sensor supply 10 VDC / 50 mA at a device supply of 24 VDC		●						●			
Analog output 0-10 VDC, 0/4-20 mA at a device supply of 230 VAC	●	●	●	●	●	●	●		●		
Analog output 0-10 VDC, 0/4-20 mA at a device supply of 24 VDC		●	●	●	●	●	●	●	●		
2 Relay outputs	●	●	●	●	●	●	●	●	●	●	●
Voltage supply 24 VAC or 115 VAC		●	●	●	●	●	●	●	●	●	●
Dimension strip custom-made	●	●	●	●	●	●	●	●	●	●	●

Connection examples

M2-devices with a direct current/direct voltage input and sensor supply

2-wire sensor: 4-20 mA

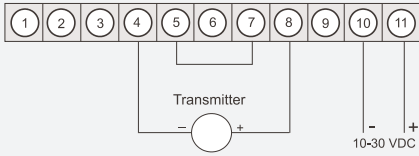

3-wire sensor: 0-20 mA

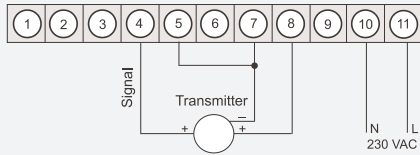
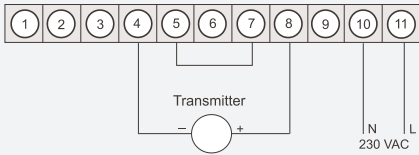
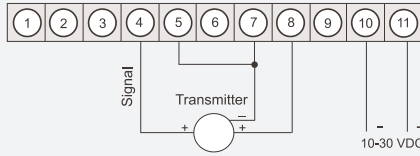

3-wire sensor: 0-10 V

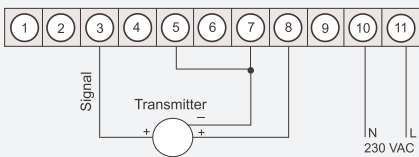
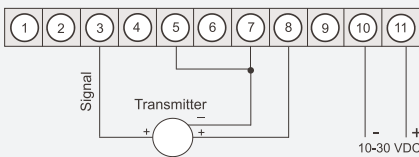

M2-devices with frequency or impulse output

Namur

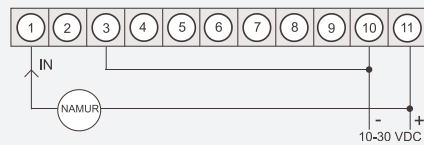

Namur

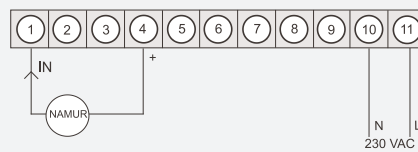

3-wire NPN

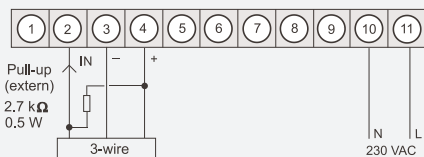

3-wire NPN

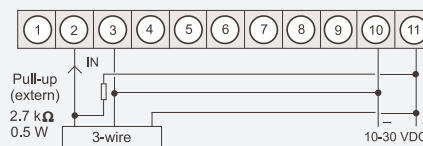

3-wire PNP



3-wire PNP

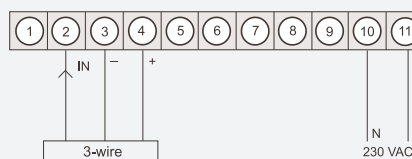

Technical Data

Dimensions

Case	B96 x H48 x D70 mm, (including plug-in terminal D=89 mm)
Panel cut-out	92.0 +0.8 x 45.0 +0.6 mm
Fixing	Screw elements for insulation thickness up to 3 mm
Case material	PC Polycarbonate, black
Sealing material	EPDM, 65 Shore, black
Protection class	At the front IP65 Standard Backside IP00
Weight	Approx. 200 g
Connection	Plug-in terminal; line cross-section up to 2.5 mm ²

Display

Display	5-digit
Digit height	14 mm
Segment colour	Red (standard), optional available in green, blue and orange
Display range	-1999 to 9999
Setpoints	Optical display flashing
Overflow/Underflow	Horizontal bars at the top/ horizontal bars at the bottom
Display time/Measuring time	0.1 to 10.0 seconds

Measuring input

M2-1VR5B.0001... Direct current/ Direct voltage	Span	-12 ...12 V	/-22 ...24 mA
	Measuring range	0-10 VDC	/0/4-20 mA
	Input resistance	Ri at ~200 kΩ	Ri at ~100 Ω
	Measuring error	0.1% of measuring range, +/- 1 Digit	/0.1% of measuring range, +/- 1 Digit
	Temperature drift	100ppm/K	
	Measuring time/principle	0.1 ...10.0 seconds/ U/F-conversion	
	Resolution	Approx. 18Bit at 1s measuring time	

Measuring input

M2-1VR5B.0H01... H Direct current/ Direct voltage	Span	6-600VDC	0-300VDC	0-50VDC	0-1ADC
	Input resistance	Ri at ~2 MΩ	Ri at ~1 MΩ	Ri at ~200 kΩ	Ri at ~200 kΩ
	Measuring error	0.5% of measuring range, +/- 1 Digit			
	Temperature drift	100ppm/K			
	Measuring time/principle	0.1 ...10.0 seconds/ U/F-conversion			
	Resolution	Approx. 18Bit at 1s measuring time			

Measuring input

M2-1VR5B.0002... Shunt	Span	-5 ...75mV	-15 ...180mV	-30 ...360mV	-100 ...1200mV
	Measuring range	0 ...60 mV	0 ...150mV	0 ...300mV	0 ...1000mV
	Input resistance	Ri at ~12 kΩ	Ri at ~60 kΩ	Ri at ~30 kΩ	Ri at ~200 kΩ
	Measuring error	0.2% of measuring range, +/- 1 Digit /		0.2% of measuring range, +/- 1 Digit	
	Temperature drift	100ppm/K			
	Measuring time/principle	0.1 ...10.0 seconds/ U/F-conversion			
	Resolution	Approx. 18Bit at 1s measuring time			

Measuring input

M2-1VR5B.0005... Potentionmeter	Span	>1 kΩ ...1000 kΩ
	Measuring range	0-100%
	Measuring error	0.2% of measuring range, +/- 1 Digit
	Temperature drift	100ppm/K
	Measuring time/principle	0.1 ...10.0 seconds/ U/F-conversion
	Resolution	Approx. 18Bit at 1s measuring time

Measuring input

M2-1VR5B.0x06... Resistance	Span	0...1,1 kΩ, 0...11 kΩ, 0...110 kΩ
	Measuring range	0...1kΩ, 0...10 kΩ, 0...100 kΩ
	Measuring error	0.5% of measuring range, +/- 1 Digit
	Temperature drift	100ppm/K
	Measuring time/principle	0.1 ...10.0 seconds/ U/F-conversion
	Resolution	Approx. 18Bit at 1s measuring time

Measuring input

M2-1TR5B.030C... PT100	Measuring range	-200 ...850°C/ -328 ...1562°F
	Measuring error	0.1% of measuring range, +/- 1 Digit
	Temperature drift	100ppm/K
	Measuring time/principle	0.1 ...10.0 seconds/ U/F-conversion
	Resolution	approx.0.1°C or 0.1°F

Measuring input

M2-1TR5B.040C... Thermocouple	Measuring range	Type L -200...900°C	Type B 80...1820°C	Type E -270... 1000°C
		Type J -210...1200°C	Type S -50...1768°C	Type T -270...400°C
		Type K -270...1372°C	Type N -270...1300°C	Type R -50...1768°C
	Measuring error	2K, +/- 1 Digit		
	Temperature drift	100ppm/K		
	Measuring time/principle	0.1 ...10.0 seconds/ U/F-conversion		
	Resolution	0.1°C		
	Characteristic curve error	> +/- 1 kΩ		
	Reference junction	Thermistor		

DIGITAL PANEL INSTRUMENTS

Technical Data

Measuring input

M2-1FR5B.0007... Frequency	Signal Impulse resistance	Impulse input, TTL, Namur, 3-wire initiator PNP/ NPN Ri at 24V/ 4 kΩ High/ Low level > 15V/ < 4V High/ Low TTL level > 4,6V/ < 1,9V 0.01 Hz selectable up to 999.99 kHz 0.05% of measuring range
	Input frequency Measuring error	

Measuring input

M2-1VR5B.0004... AC voltage	Measuring range Input resistance Measuring error	50 VDC Ri at ~200 kΩ 0.5% of measuring range at 50 Hz...1 kHz up to crest factor 4 For input signals of 1...100% of final value	10 VDC Ri at ~40 kΩ	5 AAC Ri at ~0,05 Ω	1 AAC Ri at ~0,2 Ω
	Temperature drift Measuring time/ principle Resolution	100 ppm/K 0.1...10.0 seconds / U/F-conversion Approx. 18 Bit at 1s measuring time			

Measuring input

M2-1VR5B.0H04... H AC voltage	Measuring range Input resistance Measuring error	600 VAC Ri at ~2 MΩ 0.5% of measuring range at 50 Hz...1 kHz up to crest factor 4 For input signals of 1...100 % of final value	300 VAC Ri at ~1 MΩ	5 AAC Ri at ~0.05 Ω	1 AAC Ri at ~200 Ω
	Temperature drift Measuring time/ principle Resolution	100 ppm/K 0.1...10.0 seconds / U/F-conversion Approx. 18 Bit at 1s measuring time			

Measuring input

M2-1MR5B.020X... M2-1WR5B.020X...	Sensor sensitivity	1 mV/V, 2 mV/V, 3.3 mV/V
--------------------------------------	--------------------	--------------------------

Output

Relay Switching cycle	With change-over contact 250 V / 2 AAC, 30 V / 2 ACDC 0.5 * 10 ⁵ at max. contact load 5 * 10 ⁶ mechanically Separation in accordance with DIN EN50178 / Specifications in accordance with DIN EN 60255
Analog output Sensor supply	0-10 VDC, 0/4-20 mA (16 Bit) switchable 24 VDC / 50 mA 10 VDC / 20 mA
Bridge supply	10 VDC / 20-40 mA / 250-500 Ω

Digital input

Input	< 2.4 V/OFF; 10 V ON; max.30 VDC Ri at ~5 kΩ
-------	---

Power pack

Supply	230 VAC +/- 10% (max. 10 VA) 10 - 30 VDC galvanic insulated (max.4 VA)
--------	---

Memory

EEPROM Data life	≥ 100 years
---------------------	-------------

Ambient conditions

Working temperature	0 to +60 °C
Storing temperature	-20 to +80
Climatic density	Relative humidity 0-85% on years average without dew

Dimensions

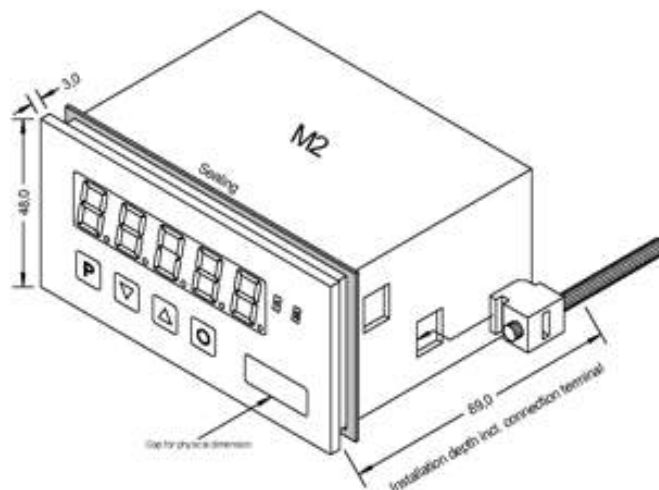

Ordering code M2-Digital display standard

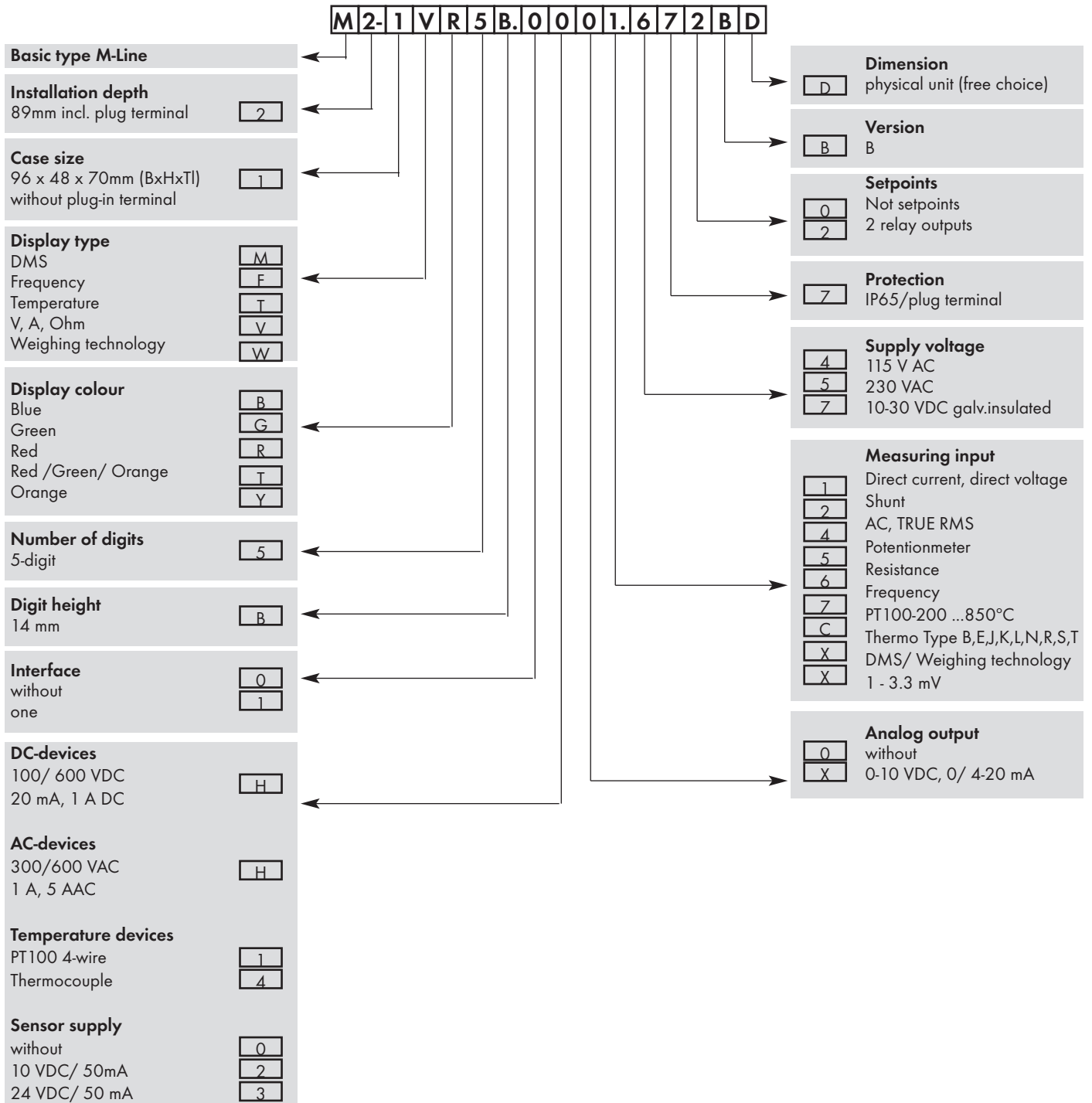

M2-2VR4C



Programmable Digital Panel 96 x 96 mm



- Digit: 20 mm
- Colour: Red
- Range of display: -999...9999
- Case: black, made of LEXAN 500R
- Protection class: IP65 (front), IPO0 (back)
- Dimensions: 96 x 96 mm, depth 75 mm, including plug-in terminal
- Supply: 230 VAC
- Sensor supply: 24 V / 50 mA
- Measuring input: 0-10 VDC, 0/4-20 mA
- 2 relay outputs
- 10 point linearization
- Offset allowance
- Tara- / Hold-function

M2-2VR4C

Case 96 x 96 mm

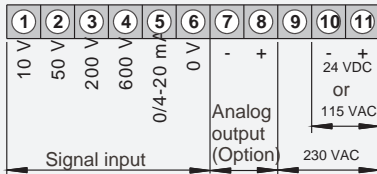

Order number (without options)

M2-2VR4C.0301.572AD

Connection pictures by use of sensor supply

2-wire sensor 4-20 mA

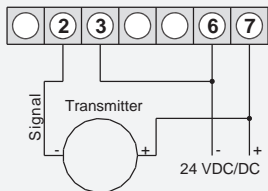

3-wire sensor 0-20 mA

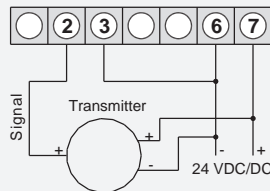

3-wire sensor 0-5 V / 0-10 V

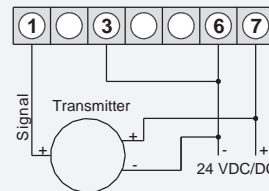

Technical Data					
Dimensions					
Case	B96 x H96 x D75 mm, (including plug-in terminal)				
Installation depth	49mm absolute case depth; 69mm including plu-in terminal				
Panel cut-out	91.0 +0.6 x 91.0 +0.6 mm				
Wall thickness	Up to 10mm				
Fixing	Fastening element, fixable via screws				
Material	LEXAN 500R, black				
Weight	Approx.370 g				
Connection	Removable screw terminal; line cross section up to 2.5 mm ²				
Installations grate	Horizontally 120mm/ vertically 120mm recommended				
Display					
Digit height	20 mm				
Segment colour	Red				
Display range	-999 to 9999				
Setpoints	One LED per set points				
Overflow/Underflow	Horizontal bars at the top/ horizontal baras at the bottom				
Display time	0.1 to 10.0 seconds				
Inputs					
Measuring range	Measuring range	Ri approx	Measuring error	Digit	
	0...10V	150 kΩ	0.1%	+/- 1	
	0...5 V	150 kΩ	0.1%	+/- 1	
	0...20 mA	150 Ω	0.1%	+/- 1	
	4...20 mA (at measuring time = 1 second)	150 Ω	0.1%	+/- 1	
	Temperature drift	all measuring input	100ppm/K		
	Measuring time = display time	0.1 ...10.0 seconds			
	Measuring principle	Voltage-Frequency converter			
	Resolution (at measuring time = 1 second)	Approx. 20Bit			
Outputs					
Relay	Change-over contact				
Switching cycle	230 VAC 5 A / 30 VDC 2 A (cos = 1); with ohm resistive burden 0.5* 10 ⁵ at max. contact rating 5* 10 ⁶ mechanically Separation according to DIN EN 50178 Specification according to DIN EN 60255				
Supply (galvanic insulated)	24 VDC; 50 mA				
Power pack					
Voltage (galvanic insulated)	230 VAC/ 50/ 60 Hz/+/- 10%				
Power consumption	max. 8 VA				
Memory					
EEPROM					
Data life	> 20 years				
Ambient conditions					
Working temperature	0 to +60 °C				
Storing temperature	-20 to +80				
Climatic density	Relative humidity 0-85% on years average without dew				
EMV					
	DIN 61326				
CE-sign					
	Conformity according to 2004/108/ EG				
Safety standard					
	DIN 61010				

MB1



Processor-based bargraph vertical or horizontal 96 x 24



- Red display, optional green or orange
- 30 point bargraph display
- Adjustable via HEX switch and push-button
- pre-adjusted input for standard signals 0-10 V and 0/4-20 mA ex works
- free adjustment on the input signal
- Different display types adjustable as bar, dot/point or curtain
- Free choice of direction and display of centre
- Control of bightness level in stages
- Protection class IP65
- Plug-in terminal

Direct current, direct voltage

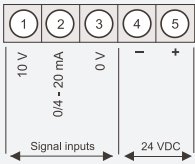

Supply		Order number (without options)
24 VDC	Horizontal Vertical	MB1-33RHO.0001.770AD MB1-33RVO.0001.770AD

OPTIONS

Availability

OPTIONS	Availability
Green bargraph display	●
Orange bargraph display	●
Multicolour	●

Connection pictures

2-wire: 4-20 mA

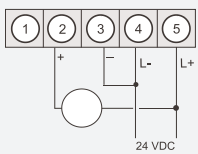

3-wire: 0/4-20 mA

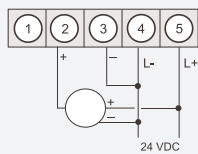

3-wire: 0-10 V

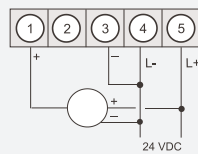

Dimensions

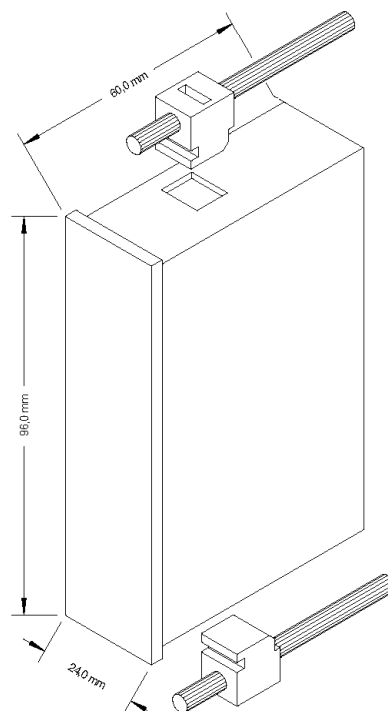

M3-7V.../M3-7T



Programmable Digital Panel 48 x 24 mm



- Red display of -1999 up to 99999 (optional green, orange or blue display)
- Minimal installation depth: 90 mm without plug-in terminal
- Min-/max-memory
- 30 additional adjustable setpoints
- Display flashing at threshold exceedance / undershooting
- Hold -and tara- function
- Permanent min-/max-value recording
- Adjustment via factory default or directly on the sensor signal
- Volume measurement (totalizator)
- Mathematical functions like reciprocal value, square root, square, rounding
- Programming interlock via access code
- Protection class IP65 at the front
- Pluggable screw terminal
- Optional: 2 PhotoMos-outputs
- Optional: Analog output or sensor supply
- Optional: Digital input

M3-7V...

Case 48 X 24 mm



Direct current, direct voltage

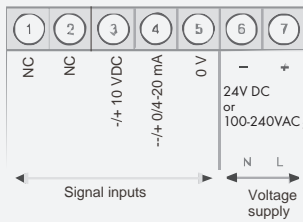

Options

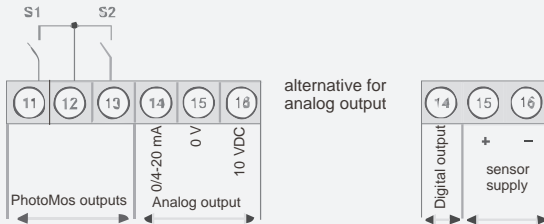

Supply

100-240 VAC
24 VDC

Order number (without options)

M3-7VR5A.0001.S70AD
M3-7VR5A.0001.770AD

Direct voltage (Shunt)

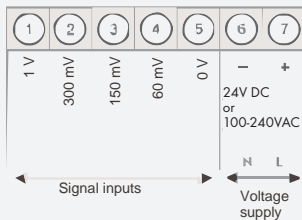

Options

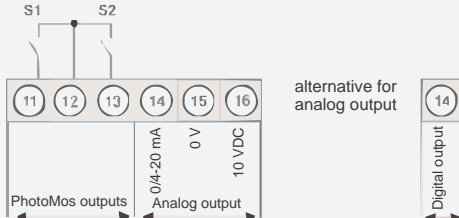

Supply

100-240 VAC
24 VDC

Order number (without options)

M3-7VR5A.0002.S70AD
M3-7VR5A.0002.770AD

Potentiometer 0 -100 % (>1 kΩ ... <1000 kΩ)

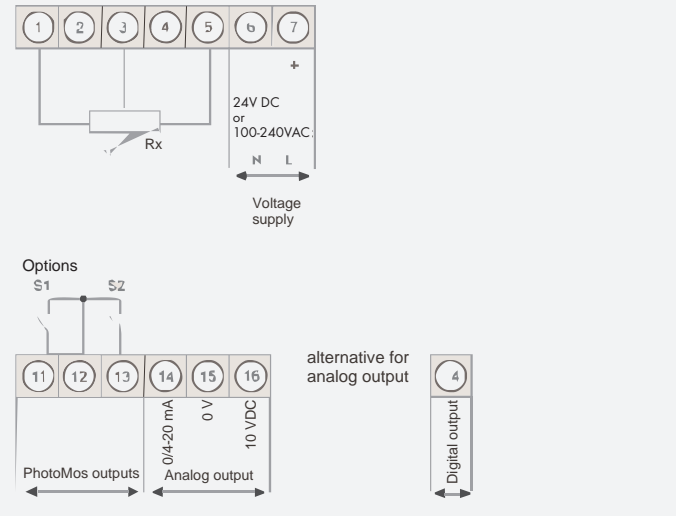

Supply	Order number (without options)
100-240 VAC 24 VDC	M3-7VR5A.0005.S70AD M3-7VR5A.0005.770AD

Resistance (1 kΩ or 10 kΩ)

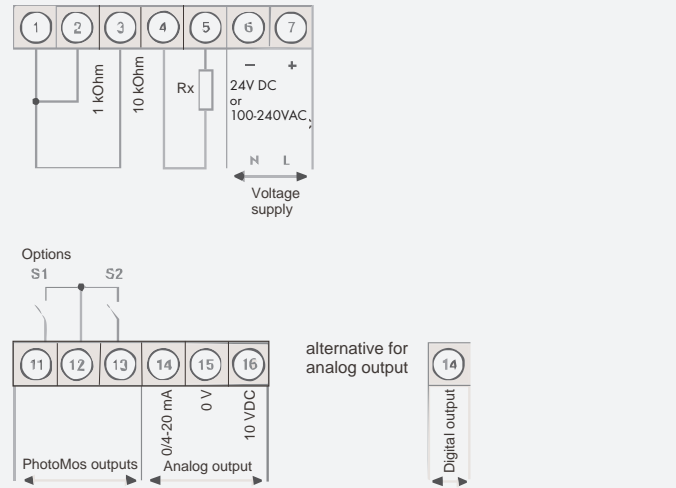

Supply	Order number (without options)
100-240 VAC 24 VDC	M3-7VR5A.0006.S70AD M3-7VR5A.0006.770AD

PT100(2-/3-/4-wire) -200°C..850°C/-328°F..1562°F

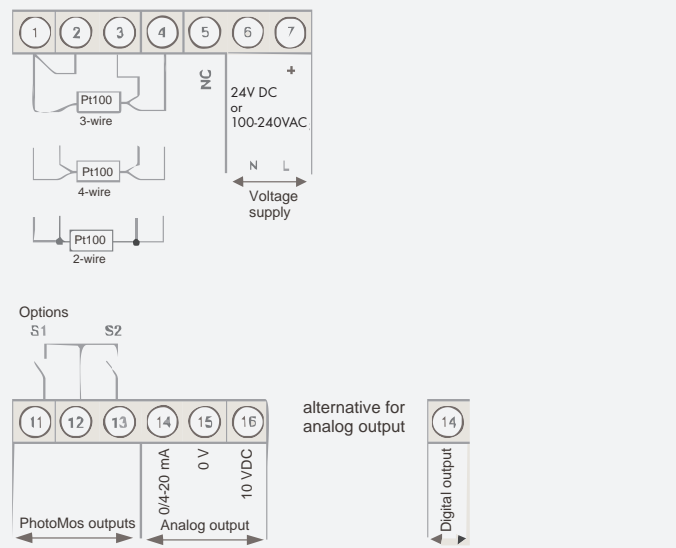

Supply	Order number (without options)
PT100 2-/4-wire 100-240 VAC 24 VDC	M3-7TR5A.010C.S70AD M3-7TR5A.010C.770AD
PT100 3-wire 100-240 VAC 24 VDC	M3-7TR5A.030C.S70AD M3-7TR5A.030C.770AD

DIGITAL PANEL INSTRUMENTS

Thermocouple Type L, J, K, B, S, N, E, T, R

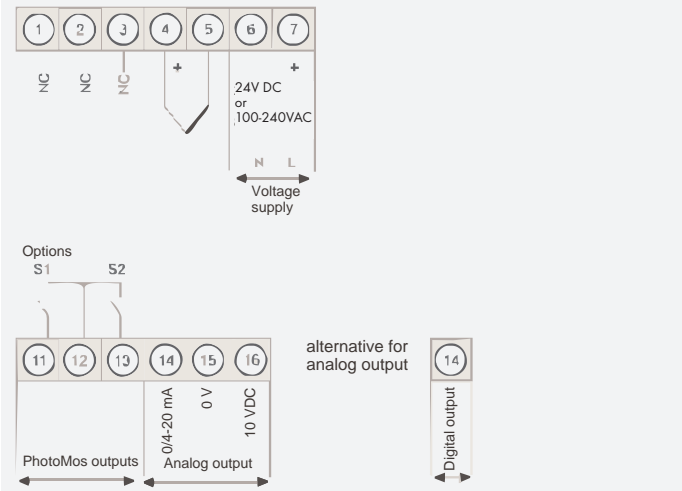

Supply	Order number (without options)
100-240 VAC 24 VDC	M3-7TR5A.040X.S70AD M3-7TR5A.040X.770AD

Frequency (0.01 Hz to 999.99 kHz)

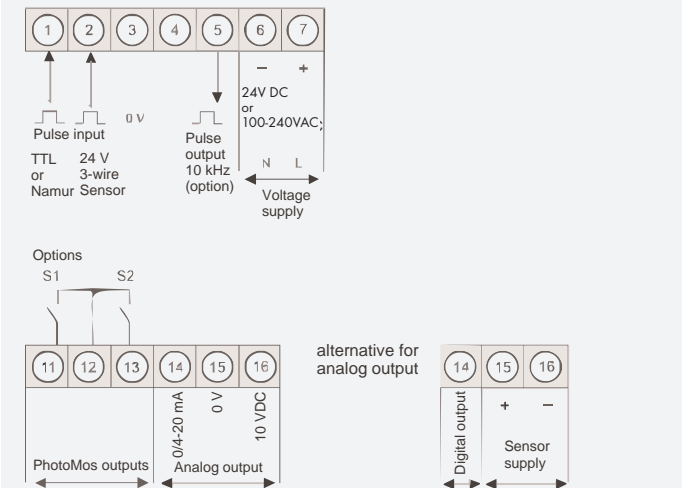

Supply	Order number (without options)
100-240 VAC 24 VDC	M3-7FR5A.0007.S70AD M3-7FR5A.0007.770AD

Connection pictures

M3 devices with current input/ volatge input

M3 devices with current input/ volatge input and sensor supply

M3 in combination with a 2-wire sensor 4-20 mA

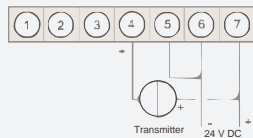

M3 in combination with a 3-wire sensor 0/4-20 mA

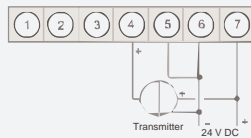

M3 in combination with a 3-wire sensor 0-10 V

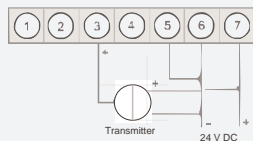

Connection pictures

M3 devices with frequency input/ pulse input

Namur

lower terminal

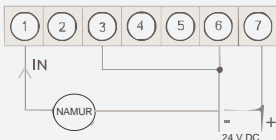

Namur

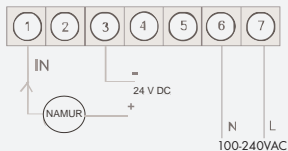

3-wire PNP

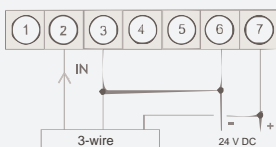

3-wire PNP

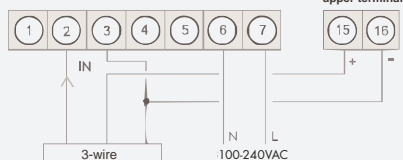

3-wire NPN

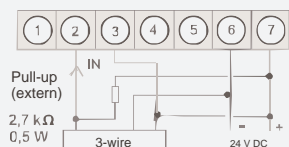

3-wire NPN

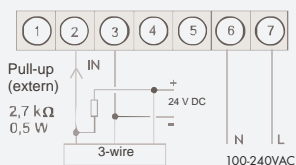

OPTIONS

Availability

OPTIONS	Availability						
	<i>Direct current/voltage</i>	<i>Shunt</i>	<i>Potentiometer</i>	<i>Resistance</i>	<i>PT100</i>	<i>Thermo couple</i>	<i>Frequency</i>
Blue LED	●	●	●	●	●	●	●
Orange LED	●	●	●	●	●	●	●
Green LED	●	●	●	●	●	●	●
Digital input	●	●	●	●	●	●	●
Sensor supply 10 VDC / 20 mA incl. digital input at a device supply of 24 VAC	●						●
Sensor supply 24 VDC / 50 mA incl. digital input at a device supply of 24 VAC	●						●
Sensor supply 24 VDC / 50 mA incl. digital input and impulse output at a device supply of 24 VAC							●
Analog output 0-10 VDC, 0/4-20 mA at a device supply of 24 VAC	●	●	●	●	●	●	●
2 PhotoMos outputs	●	●	●	●	●	●	●
Without keypad, operation on the back	●	●	●	●	●	●	●
Voltage supply 24VDC or 100-240 VAC	●	●	●	●	●	●	●

DIGITAL PANEL INSTRUMENTS

Technical Data

Dimensions

Case	B48 x H24 x D90 mm, (including plug-in terminal D=109 mm)
Panel cut-out	45.0 +0.6 x 22.2 +0.3 mm
Fixing	Screw elements for wall thickness up to 3 mm
Case material	PC Polycarbonate, black
Sealing material	EPDM, 65 Shore, black
Protection class	At the front IP65 Standard At the back IP00
Weight	Approx. 200 g
Connection	Plug-in terminal; line cross-section up to 2.5 mm ²

Display

Display	5-digit
Digit height	10 mm
Segment colour	Red (standard), optional available in green, blue and orange
Display range	-19999 to 99999
Setpoints	Optical display flashing
Overflow/Underflow	Horizontal bars at the top/ horizontal bars at the bottom
Display time/Measuring time	0.1 to 10.0 seconds

Measuring input

M3-7VR5A.0001...	Span	-12 ...12 V	/-22 ...24 mA
Direct current/ Direct voltage	Measuring range	0-10 VDC	/0/4-20 mA
	Input resistance	Ri at ~200 kΩ	Ri at ~100 Ω
	Measuring error	0.1% of measuring range, +/- 1 Digit	/0.1% of measuring range, +/- 1 Digit
	Temperature drift	100ppm/K	
	Measuring time/principle	0.1 ...10.0 seconds/ U/F-conversion	
	Resolution	Approx. 18Bit at 1s measuring time	

Measuring input

M3-7VR5A.0002...	Span	-5 ...75mV	-15 ...180mV	-30 ...360mV	-100 ...1200mV
Shunt	Measuring range	0 ...60 mV	0 ...150mV	0 ...300mV	0 ...1000mV
	Input resistance	Ri at ~12 kΩ	Ri at ~60 kΩ	Ri at ~30 kΩ	Ri at ~200 kΩ
	Measuring error	0.2% of measuring range, +/- 1 Digit/			
	Temperature drift	100ppm/K			
	Measuring time/principle	0.1 ...10.0 seconds/ U/F-conversion			
	Resolution	Approx. 18Bit at 1s measuring time			

Measuring input

M3-7VR5B.0005...	Span	>1 kΩ ...1000 kΩ
Potentiometer	Measuring range	0-100%
	Measuring error	0.2% of measuring range, +/- 1 Digit
	Temperature drift	100ppm/K
	Measuring time/principle	0.1 ...10.0 seconds/ U/F-conversion
	Resolution	Approx. 18Bit at 1s measuring time

Measuring input

M3-7VR5A.0x06...	Span	0...1,1 kΩ, 0...11 kΩ
Resistance	Measuring range	0...1kΩ, 0...10 kΩ
	Measuring error	0.1% of measuring range, +/- 1 Digit
	Temperature drift	100ppm/K
	Measuring time/principle	0.1 ...10.0 seconds/ U/F-conversion
	Resolution	Approx. 18Bit at 1s measuring time

Measuring input

M3-7TR5A.010C...	Measuring range	-200 ...850 °C/ -328 ...1562 °F
PT100	Measuring error	0.1% of measuring range, +/- 1 Digit
	Temperature drift	100ppm/K
	Measuring time/principle	0.1 ...10.0 seconds/ U/F-conversion
	Resolution	0.1 °C or 0.1 °F

Measuring input

M3-7TR5A.040X...	Measuring range	Type L -200...900 °C	Type B 80...1820 °C	Type E -270... 1000 °C
Thermocouple		Type J -210...1200 °C	Type S -50...1768 °C	Type T -270...400 °C
		Type K -270...1372 °C	Type N -270...1300 °C	Type R -50...1768 °C
	Measuring error	2K, +/- 1 Digit		
	Temperature drift	100ppm/K		
	Measuring time/principle	0.1 ...10.0 seconds/ U/F-conversion		
	Characteristic line error	< +/- 1K		
	Resolution	0.1 °C		
	Reference junction	Thermistor		

Measuring input

M3-7FR5A.0007...	Signal	Pulse input, TTL, Namur, 3-wire initiator PNP/ NPN
Frequency	Input resistance	Ri at 24V/ 4 kΩ High/ Low level > 15V/ < 4V High/ Low TTL level >4.6V/ <1.9V
	Input frequency	0.01 Hz selectable up to 999.99 kHz
	Measuring error	0.05% of measuring range

Output

PhotoMos	Closer contact: 30VDC/ AC, 0.4A
Pulse output	Max. 10 KHz (only with frequency metering)
Analog output	0-10 VDC, 0/4-20 mA (16 Bit) switchable
Sensor supply	24 VDC/ 50 mA 10 VDC/ 20 mA

Technical Data		
Digital input	Input	< 2.4 V/OFF; 10 V ON; max.30 VDC Ri at ~ 5 kΩ
Power pack	Supply	100-240 VAC 50/60 Hz / DC +/- 10% (max.5 VA) 24 VDC +/- 10%, galvanic insulated (max.4 VA)
Memory	EEPROM Data life	≥ 100 years
Ambient conditions	Working temperature Storing temperature Climatic density	0 to +50°C -20 to +80 Relative humidity 0-85% on years average without dew
CE-sign	Conformity to 2004/ 108/ EG	
EMV	EN 61326	
Safety standard	EN 61010	

Ordering code M3-Digital display standard

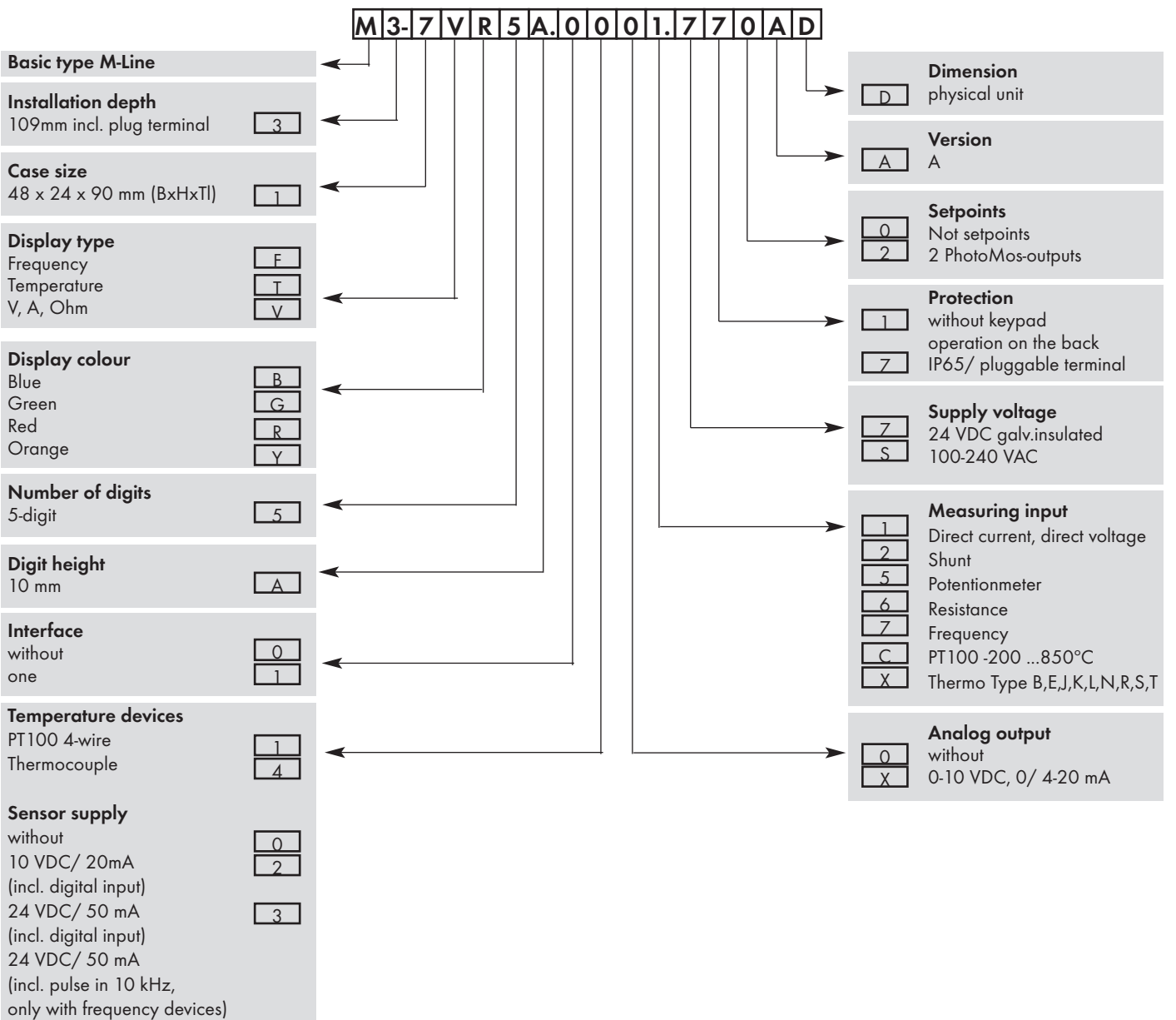

PVE4

Programmable Digital Panel Instrument 72 x 36 mm



Digital processor-controlled panel meter

- Isolated
- 2 free scalable setpoints/hysteresis
- analog output galvanic insulated
- Min/Max memory

Digit height 14,0 mm

PVE4

Case 72 x 36 mm



Alternating voltage, alternating current

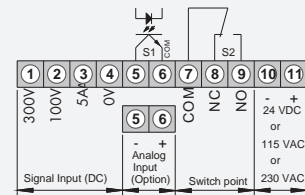

Supply		Order number (without options)
230 VAC	Standard	PVE 4.004.6522C
	True effective value RMS	PVE 4.104.6522C
115 VAC	Standard	PVE 4.004.6422C
	True effective value RMS	PVE 4.104.6422C
24 V DC (galvanic insulated)	Standard	PVE 4.004.6722C
	True effective value RMS	PVE 4.104.6722C

Options PVE

	PVE 4.004.... Alternating current
Green LED	●
Protection IP54 at the front	●
Protection IP65 at the front	●
Plug-in terminal	●
With analog output there is no setpoint S1!	●
Analog output 0-10 V DC/ 12 bit (supply voltage 230/ 115 V AC)	●
Analog output 0-20 mA/ load 500Ω/ 12 bit (supply voltage 230/ 115 V AC)	●
Analog output 4-20 mA/ load 500Ω/ 12 bit (supply voltage 230/ 115 V AC)	●
Analog output 0-10 V DC/ 12 bit (supply voltage 24 V DC galvanic insulated)	●
Analog output 0-20 mA/ load 500Ω/ 12 bit (supply voltage 24 V DC galvanic insulated)	●
Analog output 4-20 mA/ load 500Ω/ 12 bit (supply voltage 24 V DC galvanic insulated)	●
The analogue output is galv.insulated from the measuring input!	●
Dimension strips selectable (max. 7 signs)	●
Measuring range 1 A on demand (S108)	●
Other power supplies on demand	●

Ordering code PVE

Digital panel instrument with microprocessor based technology and 2 setpoints (standard)

P V E 4 0 0 4 6 5 2 2 C

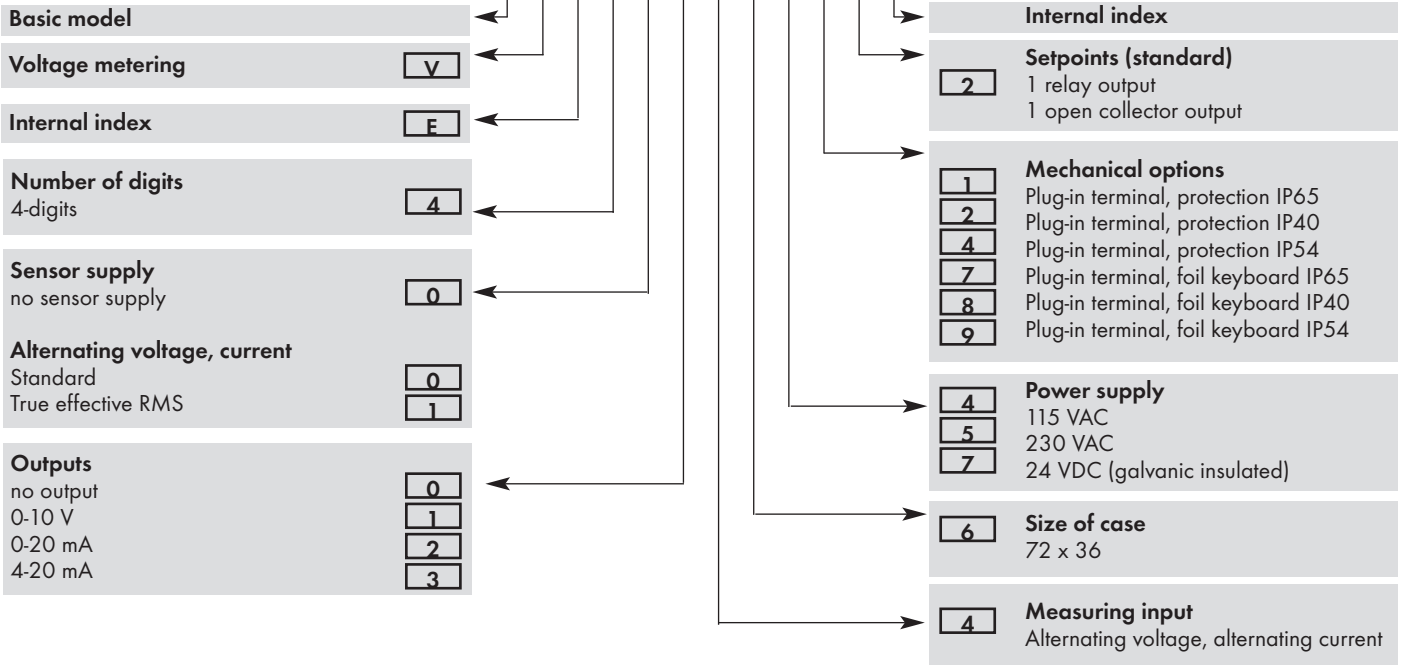

Dimensions

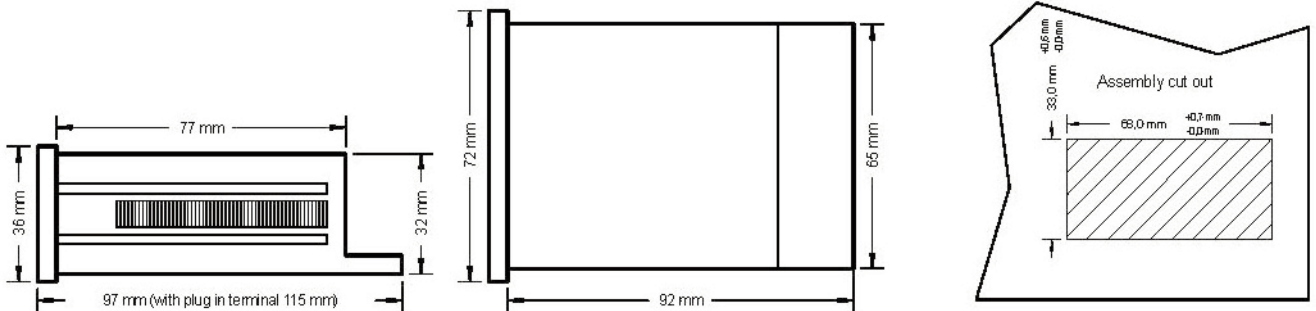

DIGITAL PANEL INSTRUMENTS

Technical Data

Dimensions

Housing	B72 x H36 x D97 mm, (including plug-in terminal D=115 mm)
Panel cut-out	68.0 +0.7 x 33.0 +0.6 mm
Fixing	Special quick plastic clamp proper to fix in wall up to 50 mm
Housing material	PC/ABS-plastic blend, UL94V-0, black
Protection class	At the front IP40 At the back IP00
Weight	Approx. 200 g
Connection	at the rear via terminals up to 2.5 mm ²

Input

PVE4.004... Alternating current/ Alternating voltage	Measuring range	100V, 300V, 5A - Optional 1A all range selectable via connection terminal
	Input resistance	Ri with 100V= ~1MΩ 1A= ~276mΩ 300V= ~4MΩ 5A= ~56mΩ

Output

For all versions	Relay outputs (Switching cycle)	charge 240 VAC/ 0.25A - 24VDC/ 1A, with ohm resistive burden 2*10 ² at max. contact rate 10*10 ³ mechanically
	Open collector Analog output	Supply by customers (U _B = 5-35V (I _{max} = 100A with U _{CE sat}) 0-10 VDC (12 Bit) 0-20 mA (12 Bit) load max. 500Ω 4-20 mA (12 Bit) load max. 500Ω The analog output is galvanic insulated from the measuring input!

Accuracy

PVE4.0x4...	Resolution	-999...9999 Digit
	Measuring fault	+/- 1.0% of final value, +/- 1 digit
	Measuring principle (input)	precision rectifier - effective value with sine waveform only
	Frequency range	Nominal precision 40Hz up to 1000Hz
PVE4.1x4...	Measuring fault	+/- 0.7% of final value, +/- 1 digit, crest factor 3
	Measuring principle (input)	True effective value RMS
	Frequency range	Nominal precision 40Hz up to 1000Hz
PVE4.004... For AC versions	Measuring principle	I ~ 200 ppm/K / U ~ 100 ppm/K Voltage/ frequency converter

Power unit

Supply voltage	230/ 115 VAC +/- 10% (50-60Hz), 24 VDC +/- 10% galvanic insulated
Power consumption	max. 3VA

Indication

	Display	LED with 7 segments, 14mm high, red 4-digit = indication 9999
For all versions	Ovrflo	indication of 4 transversal bars
For all versions	Indication time	from 0.1 up to 10 seconds adjustable

Ambient conditions

Working temperature	0 up to +60°C
Storing temperature	-20 up to +80°C

